



CITY OF PINOLE

## **REQUEST FOR PROPOSALS (RFP)**

### **ENGINEERING SERVICES FOR THE SS2203 EFFLUENT OUTFALL VAULT IMPROVEMENTS PROJECT**

**RFP No: PW-2024-04**

**Date released: March 27, 2024**

City of Pinole  
2131 Pear Street  
Pinole, CA 94564

#### **Proposal Submission Deadline:**

Proposals are due prior to 4:00 PM, Pacific Standard Time

**April 30, 2024**

## TABLE OF CONTENTS

### ENGINEERING SERVICES FOR THE SS2203 EFFLUENT OUTFALL VAULT IMPROVEMENTS PROJECT

SECTION I – INTRODUCTION .....	3
SECTION II – OVERVIEW .....	5
Figure 1 – Pinole-Hercules Effluent Force Main and Deepwater Outfall Map.....	6
Table 1 – Current Capacities and Permitted Flows .....	7
Figure 2 – Exposed Force Main Photograph and Location.....	9
Figure 3 – Recommended Pump and System Curves with Outfall Vault Modifications .....	10
Figure 4 – Existing Outfall Vault Configuration .....	11
SECTION III – SCOPE OF WORK .....	13
SECTION IV – AWARD .....	16
SECTION V – PUBLIC RECORDS .....	16
SECTION VI – NON-DISCRIMINATION.....	16
SECTION VII – LEVINE ACT .....	17
SECTION VIII – DISADVANTAGED BUSINESS ENTERPRISE (DBE).....	17
SECTION IX – INDEMNIFICATION, INSURANCE, AND BONDING REQUIREMENTS.....	17
APPENDIX A – PROPOSAL REQUIREMENTS.....	18
APPENDIX B – PROPOSAL EVALUATION.....	21
APPENDIX C – COST PROPOSAL .....	23
ATTACHMENT 1 – STANDARD CONSULTING SERVICES AGREEMENT .....	24
ATTACHMENT 2 – PLANS .....	40
ATTACHMENT 3 – LINKS TO PERMITS, JPA .....	47

## SECTION I – INTRODUCTION

The City of Pinole (City) is issuing a Request for Proposals (RFP) from qualified consultants or teams to provide Engineering Services for the SS2203 Effluent Outfall Vault Improvements Project (Project). Engineering services will include preliminary and final design, including preparing plans, specifications and estimates (PS&E) and contract bid documents, and support services during the bidding and construction phases.

This Project will be funded with sewer enterprise funds requiring design and construction in accordance all pertinent local, State, and Federal laws and regulations. Completion of the construction of the project is planned by October 15, 2026 in order to meet permit provision deadlines discussed further below.

The proposals submitted in response to this RFP will be used as a basis for selecting the proposer (Consultant) to perform services. The prospective Consultant's attention is directed to Appendix A, "Proposal Requirements," of this RFP. The prospective Consultant's proposal will be evaluated and ranked according to the criteria provided in Appendix B, "Proposal Evaluation," of this RFP.

It shall be the prospective Consultant's responsibility to check the City of Pinole or Public Purchase websites to obtain any addenda that may be issued. Addenda to this RFP will be posted on the City of Pinole and Public Purchase websites found at:

[https://www.ci.pinole.ca.us/city\\_government/public\\_works/capital\\_projects/bids\\_and\\_rfps](https://www.ci.pinole.ca.us/city_government/public_works/capital_projects/bids_and_rfps)  
<https://www.publicpurchase.com>

Consultants shall submit two (2) hard copies or one (1) electronic copy in PDF format on a CD/DVD/USB Flash drive of the consultant's proposal. The hard copies and CD/DVD/USB Flash drive shall be mailed or submitted to the City of Pinole, 2131 Pear St, Pinole, CA 94564. Alternatively, the proposal (in PDF format) can be emailed to [pwrfp@ci.pinole.ca.us](mailto:pwrfp@ci.pinole.ca.us). Proposal submission in any of the methods as described above must reach us prior to **4:00 PM (local), April 30, 2024 ("Proposal Submission Deadline")**. Hard copy proposals shall be submitted in a sealed package clearly marked **"RFP No. PW-2024-04 – ENGINEERING SERVICES FOR THE SS2203 EFFLUENT OUTFALL VAULT IMPROVEMENTS PROJECT"** and addressed as follows:

Sanjay Mishra, P.E., T.E.  
Public Works Director  
City of Pinole  
Pinole, CA 94564

RFP No. PW-2024-04

Proposals received after the Proposal Submission Deadline will be considered nonresponsive and will be rejected. Any proposals received prior to the time and date specified above may be withdrawn or modified by written request of the prospective Consultant. To be considered, however, the **modified Proposal must be received by the Proposal Submission Deadline**.

Unsigned proposals or proposals signed by an individual not authorized to bind the prospective Consultant will be considered nonresponsive and will be rejected.

**Non-Commitment of the City**

This RFP does not commit the City to award a contract, to pay any costs incurred in the preparation of a proposal in response to this request or the negotiation of a contract, or to procure or contract for services. The City reserves the right to accept or reject any or all proposals received or to waive any irregularity or informality in any proposal or in the RFP procedure, and to be the sole judge of the responsibility of any proposer and of the suitability of the services to be rendered. Further, City reserves the right to negotiate with any qualified Consultant, or to modify or cancel in part or in its entirety the RFP if it is in the best interests of the City to do so. Furthermore, a contract award may not be made based solely on price.

The prospective Consultant is advised that should this RFP result in recommendation for award of a contract, the contract will not be in force until it is approved and fully executed by the appropriate authority and/or City Council.

All products used or developed in the execution of any contract resulting from this RFP will remain in the public domain at the completion of the contract.

**PROCUREMENT SCHEDULE**

The anticipated Consultant selection schedule is as follows:

Issue Date	March 27, 2024
Deadline for Submitting Written Questions	2:00 PM (local) April 16, 2024
Answers to Written Questions Posted	April 19, 2024
<b>Proposal Submission Deadline</b>	<b>4:00 PM (local), April 30, 2024</b>
Tentative Interview Date	TBD
Final Selection	TBD
Tentative Contract Award	May 21, 2024

Any questions related to this RFP shall be submitted in writing to Sanjay Mishra, Public Works Director, via email at [pwrfp@ci.pinole.ca.us](mailto:pwrfp@ci.pinole.ca.us). Response to questions will be in accordance with the Procurement Schedule for this RFP. No oral question or inquiry about this RFP will be accepted.

## SECTION II – OVERVIEW

The City seeks a qualified consultant or team to provide engineering services to design and support the bidding and construction phases of one Capital Improvement Plan (CIP) project, SS2203 Effluent Outfall, which is now named SS2203 Effluent Outfall Vault Improvements Project. The primary objective of the Project is to improve the reliability and increase the discharge capacity of the Pinole-Hercules WPCP through the Effluent Force Main and Deepwater Outfall from 11.5 million gallons per day (mgd) to 13.9 mgd. The capacity improvement is required in accordance with the waste discharge requirements (WDRs) for the Pinole-Hercules WPCP in California Regional Water Quality Control Board Order R2-2023-008, NPDES Permit CA0037796 (Pinole-Hercules Permit), available at the link included in Attachment 3.

The successful Consultant will have significant experience with engineering design, bidding, and construction phase consulting services for large-diameter (24-inch diameter or greater) sanitary sewer force main and vault improvements requiring development of detailed construction sequencing and constraints, treatment plant coordination and bypass pumping to keep the pipelines in service during construction. This Request for Proposal (RFP) defines the scope of services and outlines the requirements that must be met by consultants interested in providing such services.

### PROJECT BACKGROUND

***Pinole-Hercules WPCP.*** The Pinole-Hercules WPCP, located at the foot of Tennent Avenue in the City of Pinole, treats all of the residential and commercial wastewater generated in Hercules and most of the wastewater generated in Pinole. In 2019, the City completed a full-scale upgrade of nearly every treatment process and the Effluent Pump Station. After the activated sludge biological treatment system, water is disinfected and dechlorinated and pumped into the deep waters of San Pablo Bay through the effluent force main (Pinole-Hercules Effluent Force Main) and Rodeo Sanitary District's Deepwater Outfall (Deepwater Outfall). Figure 1 below is a map showing the locations of the Pinole-Hercules Effluent Force Main and Deepwater Outfall. There are three (3) 400 HP effluent pumps at the Effluent Pump Station, which were designed to meet the peak hour wet weather treatment capacity of 20 mgd. During the design phase of the treatment plant project, an option was considered to build a 4<sup>th</sup> pump, which would be much smaller and more energy efficient for average dry weather flow. This option was not implemented at the time due to the additional cost.

***Deepwater Outfall JPA.*** City of Pinole, City of Hercules, and Rodeo Sanitary District are parties to a Joint Exercise of Powers Agreement dated August 16, 1977 (JPA) under which Rodeo Sanitary District constructed, maintains, and operates deepwater joint wastewater disposal facilities consisting of a deepwater outfall and associated onshore facilities ("disposal facilities") for the mutual benefit of the parties. The JPA is included in Attachment 3. This JPA automatically renews every 25 years and may by mutual agreement be altered, amended, and supplemented by and with the consent of the legislative or governing bodies. The modification of the deepwater outfall vault (Outfall Vault), which is part of the JPA disposal facilities, and any improvements to the Pinole-Hercules Effluent Force Main within the property boundaries of Rodeo Sanitary District may require amended or supplementary agreement(s) between these parties.

Figure 1 – Pinole-Hercules Effluent Force Main and Deepwater Outfall Map

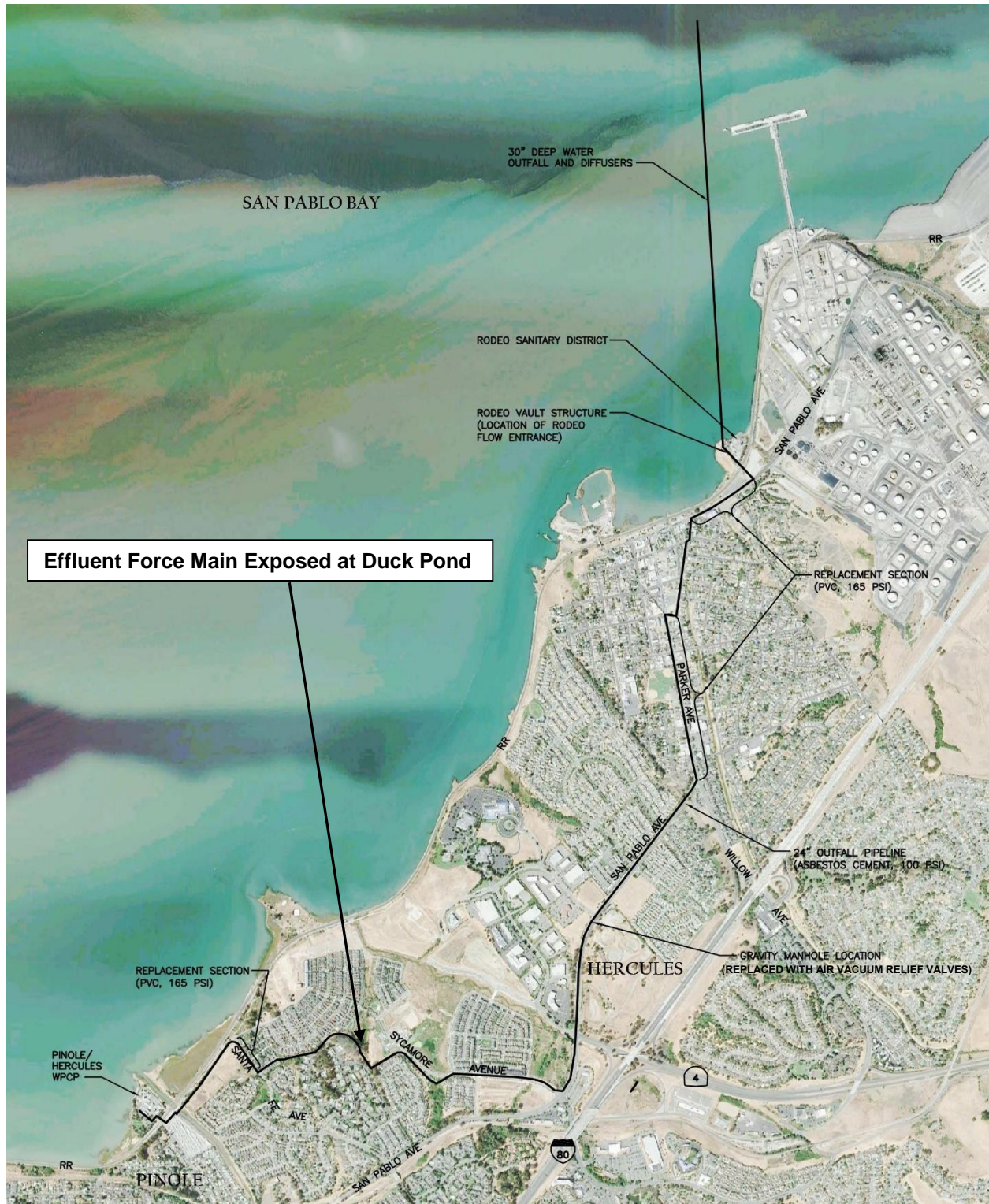

**Pinole-Hercules and Rodeo Sanitary District Current Capacities and Permitted Flows.** The current capacities and permitted flows for the Rodeo Sanitary District and Pinole-Hercules facilities discharging through the Deepwater Outfall under the JPA are included in Table 1. Additional information about these facilities continues below.

**Table 1 – Current Capacities and Permitted Flows**

Facility	Flow, mgd				Notes
	ADWF	PWWF (1-hour)	PWWF Capacity, Current	PWWF (max day), Permitted	
Rodeo Sanitary District WPCF and Effluent Force Main	1.14	3.40			
Pinole-Hercules WPCP	4.06	20.0		13.9	PWWF exceeding 13.9 mgd may be discharged through the Shallow Water Outfall
Pinole-Hercules Effluent Force Main	4.06	13.9	11.5	13.9	Effluent conveyance capacity to be increased to 13.9 mgd in accordance with Permit.
Deepwater Outfall	5.20			17	

**Pinole-Hercules Permit Requirements.** The Pinole-Hercules Permit requires secondary treatment for peak wet weather flows (PWWF) up to 20 mgd and conveyance of 13.9 mgd to the Deepwater Outfall. Flows greater than 13.9 mgd are permitted to be discharged to the Shallow Water Outfall from the WPCP (sometimes referred to as the Emergency Outfall). Pinole-Hercules Permit provisions include the following requirements:

*6.3.5.3 Corrective Measures to Reduce Use of Emergency Outfall. Prior to bringing the outfall eductor station online, the Discharger shall provide the following by June 30, 2027:*

*6.3.5.3.1. Documentation verifying completion of the plant upgrade to increase effluent conveyance capacity to the deepwater outfall, including documentation of the upgraded conveyance capacity (expected to be approximately 13.9 MGD);*

*6.3.5.3.2. Inspections, performance tests, and quality assurance/quality control checks for upgraded components;*

*6.3.5.3.3. Updates to the Operation and Maintenance Manual; and*

*6.3.5.3.4. Notification at least 30 days prior to the specific date the upgrade will go online.*

**Pinole-Hercules Effluent Force Main.** City of Pinole and City of Hercules constructed, operate, maintain, and jointly own the Pinole-Hercules Effluent Force Main from the Pinole-Hercules WPCP to the connection point with the disposal facilities. The Pinole-Hercules Effluent Force Main is a 24-inch pipeline located within Railroad Avenue, Sycamore Avenue, San Pablo Avenue, and Parker Avenue in Pinole, Hercules, and Rodeo. The original asbestos cement pipe (ACP) with a pressure rating of 100 psi was installed in 1977. Selected portions have been replaced in 2006 and 2008 with 24-inch

PVC C905 DR 25 with a pressure rating of 165 psi at the locations shown on Figure 1 above. The original force main transition from pressure to gravity at an intermediate high point was modified during the 2109 Pinole-Hercules WPCP upgrade by removing the manhole and vent and adding air vacuum relief valves. Four (4) air relief valves (ARVs) were replaced in 2018-2021 and portions of force main were replaced in 2023 with HDPE during the City of Hercules Sycamore Avenue Trunk Sewer Replacement project.

**Force Main Location Identified for Repair.** During regular operations and maintenance activities, staff identified a location where the ACP Effluent Force Main is exposed. A photograph and map of this location is shown in Figure 2.

**Rodeo Sanitary District WPCF.** Rodeo Sanitary District owns and operates the Rodeo Sanitary District Water Pollution Control Facility (Rodeo Sanitary District WPCF) located at 800 San Pablo Avenue in Rodeo. The Rodeo Sanitary District WPCF provides secondary treatment of domestic and commercial wastewater collected from its service area, including Rodeo and Tormey, unincorporated areas of Contra Costa County, and discharges to San Pablo Bay through an approximately 3,900 foot long 30-inch deepwater outfall constructed in 1979. The 120-foot diffuser includes thirty 2.5-inch diffuser ports and is located approximately 3,800 feet offshore at a depth of 16.7 feet below mean sea level. Upstream of the vault structure where the Rodeo Sanitary District and Pinole-Hercules flows combine to discharge to the deepwater outfall, Rodeo Sanitary has parallel 14-inch and 18-inch pipelines. Originally, the 14-inch pipeline contained an eductor station which allowed the Rodeo Sanitary District flow to enter the pipeline without being pumped. The eductor station and pressure sustaining valve were removed and an effluent pump station was added at Rodeo Sanitary district WPCF in 2003. During low flows, the Rodeo Sanitary District WPCF flow can enter the deepwater outfall by gravity. Flows enter and exit the vault structure in the 14-inch and 18-inch piping, as shown on Figure 3.

**Outfall Vault Recommended Improvements.** The effluent flows from Pinole-Hercules enter the Deepwater Outfall vault structure (Outfall Vault), flow through 14-inch diameter vault piping, and combine with effluent flows from Rodeo Sanitary District for discharge through the 30-inch Deepwater Outfall. During design of the Pinole-Hercules WPCP upgrade, the preliminary engineering technical memorandum on Effluent Pumping (available on the City's website) recommended Alternative 2 to increase the effluent pumping and conveyance capacity, with the pump and system curves shown on Figure 3. The recommended project would increase the current size of the piping in the Outfall Vault, shown on Figure 4, for the Pinole-Hercules Effluent Force Main from 14-inch to 24-inch diameter. The proposed piping modifications are shown on Figure 5.

**Effluent Water Quality Testing and Bypass Pumping Improvements at the Outfall Vault.** Pinole-Hercules WPCP requires new effluent water quality testing infrastructure such as appurtenances, piping and surface facilities at or near the Outfall Vault, and is also interested in the evaluation/design of a permanent bypass pumping solution as an alternative to temporary bypass pumping, in order to improve reliability and reduce risks for future maintenance and improvements. Close coordination with Rodeo Sanitary District will be required, and, depending on the improvements in the selected alternatives, approvals may be required by the District Board as well as the City Councils.

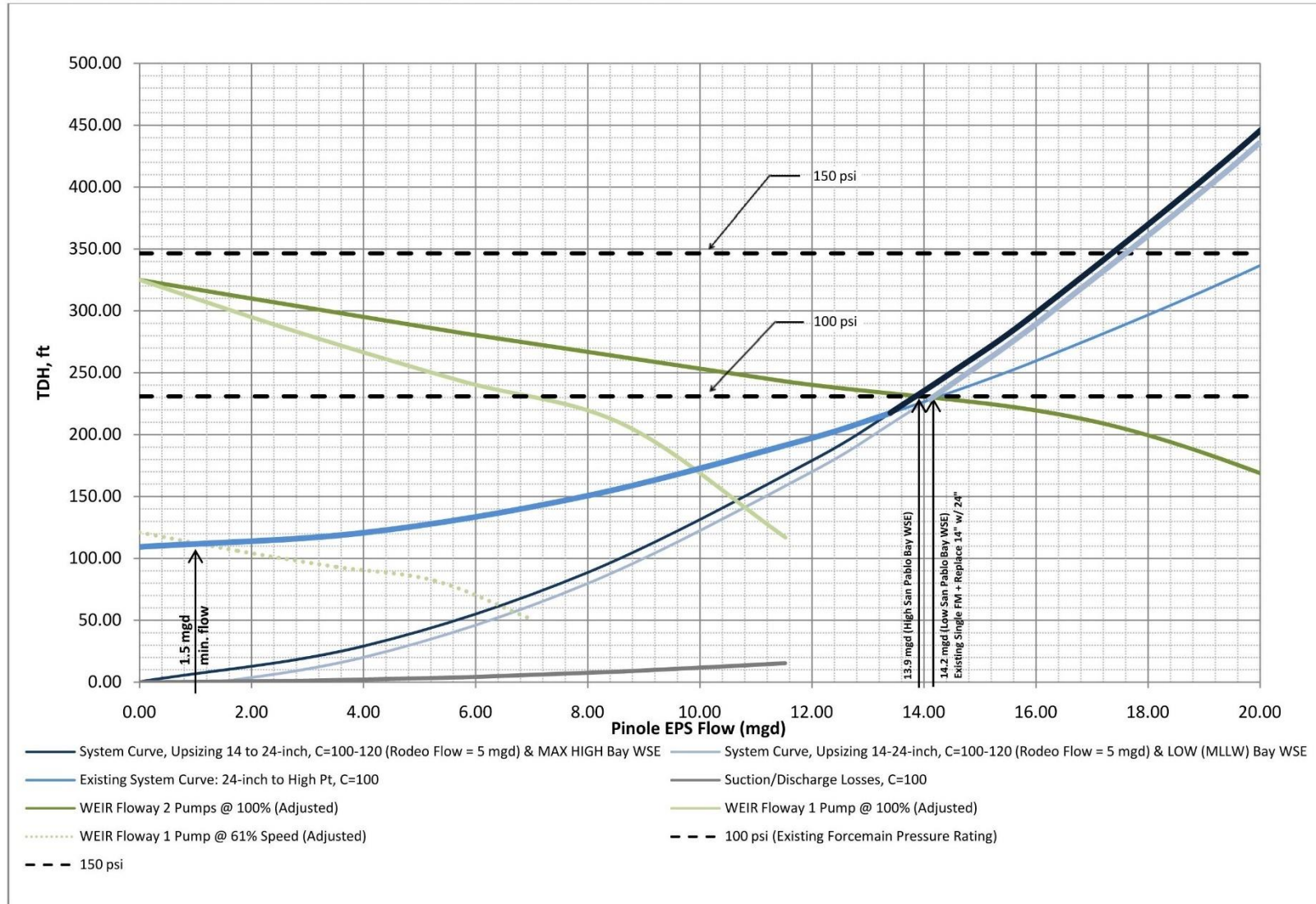

**Figure 2 – Exposed Force Main Photograph and Location**



### Figure 3 – Recommended Pump and System Curves with Outfall Vault Modifications

Figure 14-19. Recommended Alternative (Alternative 2) - Pump and System Curves



Notes:

1. Max High bay WSE = 106.10
2. MLLW = 97.10
3. Ex C Value=100 to high point and 108 (100/120) from high point to Bay
4. Replace 14" w/ 24" at Rodeo Structure

Figure 4 – Existing Outfall Vault Configuration

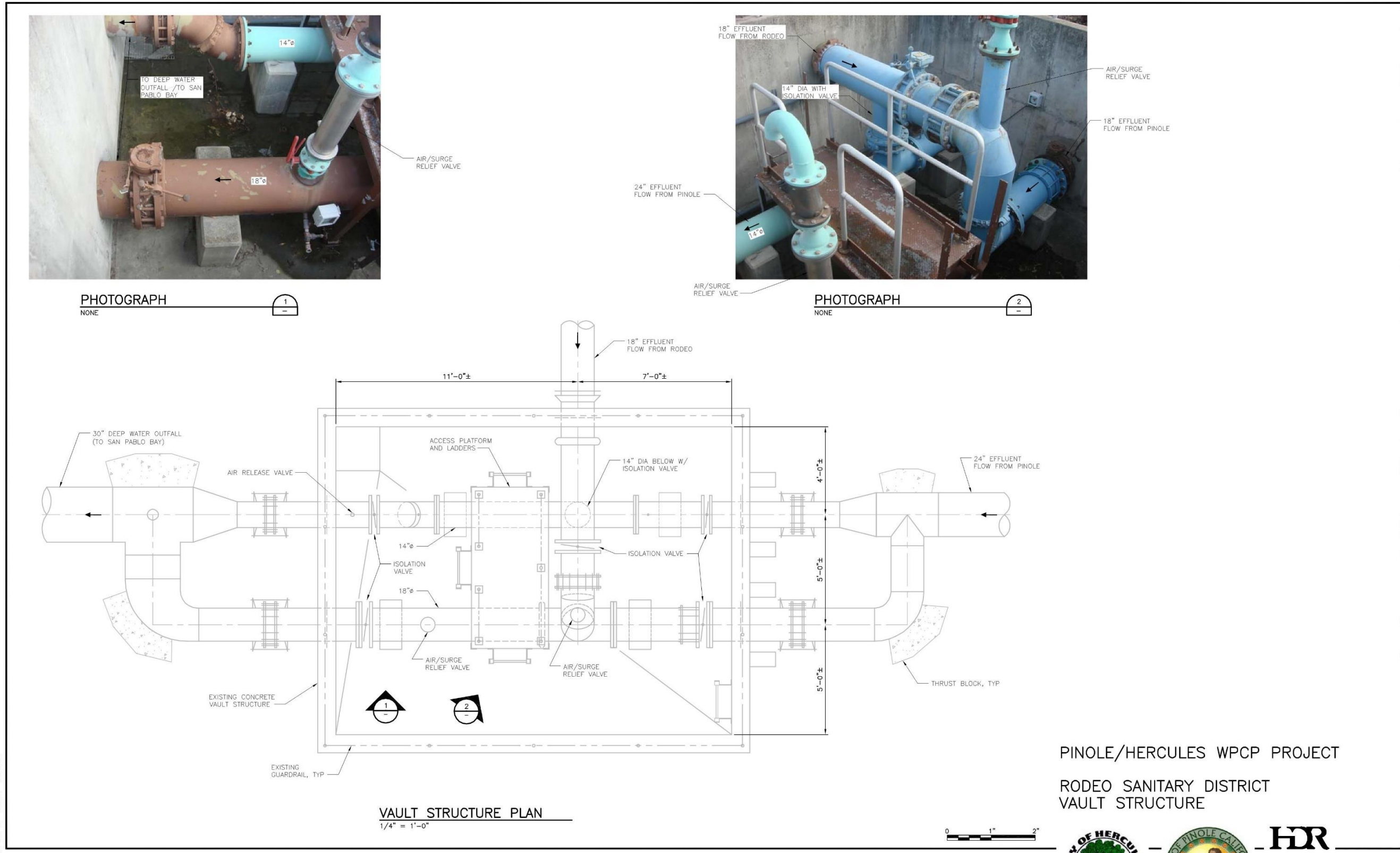

C:\working\ss2203\dwg\437083\Figure 14-08.dwg 02-28-15 BDOWN 10:57:23

PINOLE/HERCULES WPCP PROJECT  
 RODEO SANITARY DISTRICT  
 VAULT STRUCTURE

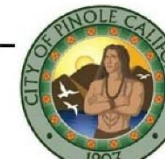
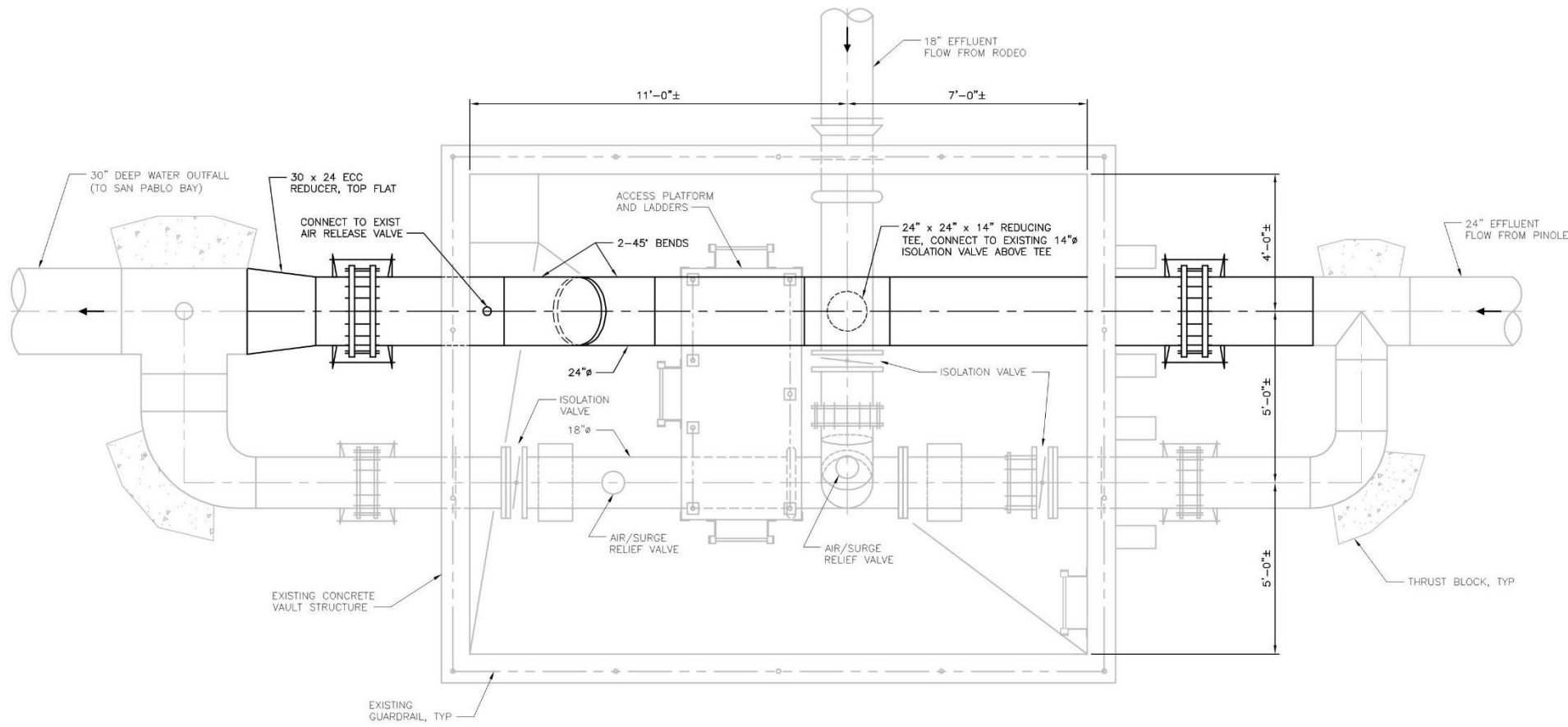

Figure 14-8

Figure 5 – Recommended Outfall Vault Modifications Plan



**VAULT STRUCTURE PIPING MODIFICATIONS PLAN**  
1/4" = 1'-0"

C:\pwworking\BSC\0437083\Figure 14-20.dwg  
02-28-13 BROWN 11:22:46

PINOLE/HERCULES WPCP PROJECT  
RODEO SANITARY DISTRICT  
VAULT STRUCTURE PIPING MODIFICATIONS

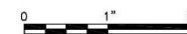

Figure 14-20

## PROJECT DESCRIPTION

The Project includes preliminary and final design services, including preparing a Preliminary Design Report (PDR), preparing plans, specifications and estimates (PS&E) and contract bid documents, and support services during the bidding and construction phases to recommend and complete recommended Effluent Outfall Vault and Effluent Force Main improvements. The City's objectives is for the Project to include:

- Effluent Pumping System – Updated documentation of the Pinole-Hercules effluent pumping system components and performance, including the improvements specifically including in this project, and consideration of the need for, advantages and disadvantages of, and recommendation for improvements and/or future projects including adding pumps at the Effluent Pump Station to improve pumping efficiencies, and adding surge protection.
- Outfall Vault – Piping modifications in the Outfall Vault at the junction of the two (2) effluent force mains and the deepwater outfall to increase the effluent pumping and conveyance capacity for the Pinole-Hercules WPCP from 11.5 mgd to 13.9 mgd. Effluent Force Main modifications adding appurtenances, piping, and surface infrastructure for effluent water quality testing.
- Bypass Pumping – Force main piping and appurtenances for bypass pumping of both effluent force mains, for future maintenance and construction and construction of this Project, or temporary bypass pumping system for construction, based on the preliminary design recommendations.
- Force Main Repair – Repair of the exposed Effluent Force Main in Duck Pond Park, Hercules.
- Other Improvements – Other effluent force main improvements recommended and selected during preliminary design.

## SECTION III – SCOPE OF WORK

The following Scope of Work defines project tasks and assigns each to their respective responsible parties. The following task descriptions are presented as information to assist consultants in preparing a proposal. In general, the scope of services is intended to provide the services required for the design, bidding, and construction support of the project. A detailed scope of services will be incorporated into the negotiated consultant agreement. The Consultant, under the supervision of, and in coordination with the City's project manager, shall be responsible for the tasks and program/document requirements as per the following tasks:

## TASK 1: PROJECT ADMINISTRATION

Consultant shall be responsible for project initiation and management activities throughout the life of the contract and the scope of activities includes, but is not limited to:

- Developing, maintaining and implementing a project work plan.
- Developing and maintaining a project schedule.
- Coordinating and being responsible for scheduling meetings, preparing and distributing minutes. The Consultant may use video or audio-conferencing software to conduct meetings as needed.
- Preparing and submitting progress reports and monthly invoices in a format approved by the City of Pinole.
- Complying with City, County, and State standards and requirements for project administration.

***Deliverables:*** Kickoff Meeting; Bi-Weekly Project Management Status Meetings; Meeting Agendas; Meeting Minutes and Action Items; Project Status Reports; Monthly Status Reports and Invoices

## TASK 2: PRELIMINARY DESIGN

Consultant shall perform preliminary design services:

- Collecting and reviewing background information including, but not limited to design/record drawings, effluent pumping system documents and data, prior technical assessment, evaluation, and design report documents.
- Interviewing staff to understand existing conditions and City and project stakeholder goals and requirements.
- Planning and performing field inspections, investigations, and assessments.
- Performing additional data collection, mapping, and surveys necessary for engineering, design, and estimates.
- Performing an updated effluent system evaluation documenting the improvements since previous technical memoranda, reviewing and finalizing recommended improvements at the outfall vault to increase capacity, evaluating and recommending alternatives for permanent effluent force main bypass pumping infrastructure (versus temporary bypass pumping during project construction), reviewing current and recommending effluent water quality testing infrastructure improvements, reviewing effluent pump station efficiency during dry and wet weather and making recommendations for planning future improvement projects, evaluating and/or recommending surge protection improvements, and other reliability improvements identified during preliminary design.
- Developing and documenting alternatives, probable construction costs, construction impacts and mitigations, selection criteria, and recommendations.
- Developing design concepts, construction scheduling, sequencing and constraints, and related activities needed to establish the parameters for final design.
- Developing 30% design level drawings for the recommended alternative.

- Preparing a Preliminary Design Report, conducting a review meeting with the City, and incorporating City comments and resubmitting.
- Preparing project documentation to support the City of Pinole compliance with Federal and State environmental regulations. The City anticipates a Categorical Exclusion (CE) determination for this project.
- Complying with City, County, and State standards and requirements for preliminary design.

***Deliverables:*** Staff Interviews, Field Investigations and Survey Data, Calculations, Draft Memoranda (if prepared prior to the report), 30% Design Drawings, Draft and Final Preliminary Design Report, Project Documentation for Environmental Compliance.

### TASK 3: DESIGN

The Consultant shall perform engineering design services:

- Designing the improvements and preparing plans, specifications, and estimates (PS&E) to achieve project objectives.
- Submitting PS&E to the City at 65%, 95%, and Final contract documents.
- Reviewing design submittals with the City and project stakeholders and incorporating comments provided by the City.
- Preparing materials for two (2) presentations to the City Councils and District Board and participating in three (3) presentations.
- Complying with City, District, County, and State requirements for design.

***Deliverables:*** 65%, 95% and Final PS&E, Review Meetings, Council and Board Presentation Materials and Presentations.

### TASK 4: BIDDING AND CONSTRUCTION PHASE SERVICES

Consultant shall perform bidding phase support services:

- Updating/packaging bidding and contract documents.
- Assisting City with responses to inquiries during the bid period.
- Assisting City with the pre-bid conference and job site tour.
- Preparing addenda for issuance, if requested, to clarify, correct, or change the bidding and contract documents.
- Preparing a bid tabulation spreadsheet.

Consultant shall perform engineering services during construction (ESDC):

- Preparing conformed plans.
- Preparing a submittal log, performing submittal reviews and preparing responses.
- Reviewing product substitution and contract change order requests.
- Preparing Request for Information (RFI) responses.
- Attending pre-construction and other construction-related meetings and site visits;
- Performing periodic site visits (not less than once per month).

- Providing recommendations to the City on all claims by Contractor relating to the acceptability of the work or the interpretation of the Contract Documents pertaining to the execution and progress of the work.
- Support final inspections and “punch list” preparation and completion.
- Reviewing, confirming accuracy and completeness of red line drawings and preparing record drawings based upon information supplied by the Contractor.

***Deliverables:*** Bid Documents, Responses to Questions, Pre-Bid Conference and Job Site Tour Attendance, Addenda, Bid Tabulation Spreadsheet, Conformed Plans and Specifications, Submittal Log, Submittal Responses, Substitution and Change Order Reviews, RFI Responses, Meetings and Site Visits, Punch List and Final Inspection Input, Record Drawings

#### **SECTION IV – AWARD**

In accordance with City’s Procurement Policies and Procedures Manual, the City will review and evaluate the Consultant proposals based on the criteria established in Appendix B. The City will enter negotiations with the highest ranked proposer(s). Again, the City reserves the right to award without interviews, based only upon the initial proposals. Each initial proposal should be submitted with the most favorable terms from both price and experience. If interviews are held, each proposer’s performance in the interview will be evaluated using the criteria in Appendix B. Performance in the interviews will be used to inform the final scoring on the criteria.

#### **SECTION V – PUBLIC RECORDS**

The City is subject to the provisions of the California Public Records Act (Govt. Code § 6250 et seq.) (the “Act”), and each proposal submitted to the City is subject to disclosure as a public record, unless the proposal or any portion thereof is exempt under the Act. If a proposer believes that any portion of its proposal is exempt from disclosure under the Act, it must clearly identify the portion(s) it believes to be exempt and identify the basis for the exemption. Each proposer bears the burden of proving any claimed exemption under the Act, and by submitting a proposal, a proposer agrees to indemnify, defend, and hold harmless the City against any third-party claim seeking disclosure of the proposal or any portions thereof.

#### **SECTION VI – NON-DISCRIMINATION**

Consultants shall not unlawfully discriminate, harass or allow harassment, against any employee or applicant for employment because of sex, sexual orientation, race, religious creed, color, national origin, ancestry, denial of family and medical care leave, medical condition (cancer/genetic characteristics) physical handicap, disability (mental or physical) including HIV and AIDS, denial of pregnancy disability leave or reasonable accommodation, marital status, age (40 and above), in the performance of City contracts. Consultant and any subconsultants shall ensure that the evaluation and treatment of their employees and applicants for employment are free from such discrimination and harassment.

Proposers shall include the non-discrimination and compliance provisions of the above clause in all subcontracts to perform work under this contract.



## **SECTION VII – LEVINE ACT**

Consultants will be required to disclose on the record any contribution of more than \$250 which they have made to a City Council Member within the twelve-month period preceding the submittal deadline of this RFP, and within the twelve-month period preceding any subsequent procurement based on this RFP. This applies to your company, any member of your team, any agents for you or other team members and to the major shareholders of any closed corporation, which is part of your team. If you have made a contribution which needs to be disclosed you must provide written notice of the date, amount and receipt of the contribution(s) to the City Manager. This information will need to be provided before the City can approve any contract.

## **SECTION VIII – DISADVANTAGED BUSINESS ENTERPRISE (DBE)**

City has adopted a Disadvantage Business Enterprise (DBE) Policy, pursuant to which the City encourages all prime Consultant proposers to utilize qualified DBE subconsultants on City Projects. City promotes the direct purchase of goods from qualified DBEs by utilizing DBE vendors when such vendors are available and the price of the goods sought is reasonable, and, for professional services contracts, City seeks the utilization of qualified DBEs when such DBEs are available. All prime consultants are required to report on DBE usage during the term of each contract.

For purposes of City's DBE Policy, a DBE shall be a "Disadvantage Business" within the meaning of 13 CFR Part 121 and California Government Code Section 14837. In the event that the City's DBE Policy conflicts with any Federal, State or other funding source's programs, policies, regulations or requirements, City shall make the DBE Policy consistent with said funding source's programs, policies, regulations and requirements to the extent permissible by law. City's DBE Policy is neutral as to race, ethnicity, national origin, age, sex, religion, sexual orientation and other protected classes. **The DBE goal for this contract is 0%.**

## **SECTION IX – INDEMNIFICATION, INSURANCE, AND BONDING REQUIREMENTS**

Insurance and bonding requirements for this maintenance service are set forth in attached *Standard Consultant Professional Services Agreement* (Attachment 1).

## APPENDIX A – PROPOSAL REQUIREMENTS

These guidelines are provided for standardizing the preparation and submission of the proposal. The intent of these guidelines is to assist Consultants in preparation of their proposals, to simplify the review process, and to help assure consistency in format and content. **The total number of pages must not be more than 20 pages. Introductory Letter, Appendices and Resumes are not included in the page count.**

Proposals shall contain the following information in the order listed:

### 1. Introductory Letter

The introductory letter shall be addressed to:

Sanjay Mishra, P.E., T.E.  
Public Works Director  
City of Pinole  
2131 Pear St, Pinole, CA 94564

RFP No. PW-2024-04

The letter shall be on Consultant's letterhead and include the proposer's contact name, mailing address, telephone number, and email address. The letter will address the proposer's understanding of the services being requested and any other pertinent information the proposer believes should be included. All addendums received must be acknowledged in the letter.

The letter shall acknowledge the acceptance to the terms and conditions of the Consulting Services Agreement (Attachment 1) and shall contain a statement that the proposal is valid for one hundred and twenty (120) days.

### 2. **Qualifications:** Related Experience and References

This section of the proposal should establish the ability of the Consultant to satisfactorily perform the required work by reasons of experience in performing work of a similar nature, demonstrated competence in the services to be provided, strength and stability of the firm, staffing capability, workload and supportive client references. Please feel free to add as many sheets of paper as you would like to your proposal to describe your qualifications and other sections covered in this RFP.

The Consultant shall:

- I. Provide a brief profile of the firm such as the types of services offered, the year founded, form of the organization (corporation, partnership, and sole proprietorship), number, size, location of offices and number of employees.
- II. Provide a general description of the firm's financial condition and identify any conditions (i.e., bankruptcy, pending litigation, planned office closures, impending merger) that may impede the Consultant's ability to complete the work.

- III. Describe the firm's experience in providing similar work and highlight the participation in such work by the proposed staff for this RFP.
- IV. Identify subconsultants, by company name, address, contact person, telephone number and their function in relating to the work under this RFP (if applicable).
- V. Provide as a minimum three (3) references for the service cited as related experience and furnish the name, title address, telephone number and email address of the person(s) at the client organization who is most knowledgeable about the work performed. The Consultant may also supply references from other work not cited in this section as related experience.

### **3. Staffing**

The Consultant shall:

1. Identify key personnel proposed to perform the work.
2. Provide brief descriptions of key personnel, detailing applicable experience.
3. If applicable, list any required licenses of key personnel needed to perform the work under this RFP.
4. Include a statement that identified key personnel will be available for the duration of the work and acknowledge that no key personnel shall be removed or replaced without the prior written concurrence of the City.

### **4. Project Approach and Work Plan**

The Consultant shall provide a brief narrative of the proposed approach for the Project. The proposer shall explain the way in which the proposer will completely and timely complete all of the tasks called for under the RFP along with an estimate of the time (project schedule) it will take to complete each task.

### **5. Schedule**

The proposal will include a schedule detailing when the specific task will be completed. Consultants should factor in additional time that may be required due to reasonably foreseeable types of delays. The proposal shall also identify all critical tasks, sequencing and critical paths required to ensure that the work is completed. The schedule shall also factor in reasonable review and feedback periods for draft deliverables by City staff and all legally mandated review period and comment period, including those that may be required by third party regulatory agencies. Consultant shall expect a 2-week turnaround time for the City's review of deliverables.

## **6. Cost Proposal**

Detailed cost estimate for specific tasks identified in the RFP and a schedule of rates for each proposed personnel that may be tasked to complete the Project. The task-specific cost estimate shall include an estimate of the number of hours per staff member by proposed task and clearly identify an hourly rate schedule for the proposed staff. Consultant rates for clerical, reproduction, and any proposed reimbursable shall also be included for each specific task.

If applicable, proposers shall submit a cost breakdown identifying items such as quantities, labor categories and rates, equipment rates, unit prices, material costs, applicable taxes, shipping, and delivery charges.

The prospective Consultant shall submit the Cost Proposal form included in Appendix C with their proposal in addition to the detailed cost estimate included in the proposal. This form will not be included in the page count limit.

## **7. Conflict of Interest Statement**

The Consultant shall disclose any financial, business, or other relationship with the City that may have an impact upon the outcome of the service contract. The Consultant shall also list current clients who may have a financial interest in the outcome of this contract or the construction Project that will follow. The Consultant shall disclose any financial interest or relationship with any construction company that might submit a bid on the construction Project.

## **8. Contract Agreement**

The Consultant shall provide a brief statement affirming that the proposal terms shall remain in effect for one hundred and twenty (120) days following the date proposal submittals are due.

## **9. Exceptions/Deviations**

The Consultant shall state any exceptions to or deviations from the requirements of this RFP. Where the Consultant wishes to propose alternative approaches to meeting the City's requirements, these should be thoroughly explained.

## APPENDIX B – PROPOSAL EVALUATION

### 1. Evaluation Process

The City will review and evaluate all proposals deemed responsive to this RFP in accordance with City's Procurement Policies and Procedures Manual. Each of the proposals will be ranked based on the criteria listed in this section.

All proposals will be evaluated by a City Evaluation Review Committee (Committee). The Committee may be composed of the City staff and other parties that may have expertise or experience in the services described herein. The Committee will review the submittals and will rank the proposals. The evaluation of the proposals shall be within the sole judgment and discretion of the Committee.

The selection process may include oral interviews, if so, Consultant will be notified of the time and place of oral interviews and if any additional information that may be required to be submitted.

The Committee will review the submittals and will rank the proposals based on the Evaluation Criteria. References will be used in evaluating the Consultant. A short list of top ranked Consultants will be compiled. City may award a contract solely based on this ranking.

If interviews are desired the Committee will interview the top-ranked Consultant. An interview will include the elements of the Evaluation Criteria as well as negotiations of the cost proposal and scope. If negotiations with the top ranked Consultant are unsuccessful, then negotiations will proceed to the next most qualified Consultant, and so on. The goal of negotiations is to agree on a final contract that delivers the services and products required at a fair and reasonable cost to the City.

Upon acceptance of a cost proposal and successful contract negotiations, the Committee will recommend a contract be awarded. An award would be made by the City Council.

### 2. Evaluation Criteria

Criteria for proposal evaluation includes Consultant's expertise, experience and training, the expertise of its key personnel along with prior contracting history, approach to the project, proposed schedule, and compliance with the RFP requirements including the terms of the attached Consulting Services Agreement. Each such factor shall be weighted by the City as follows:

**Qualifications and Staffing (40%)** – The expertise, experience and training of the Consultant and its key personnel and previous experience with similar work in similar fields and qualifications, depth, and availability of the staff that will perform the work on this project. This factor includes evaluation of the Consultant's prior contracting history and references for other municipalities.

**Project Approach and Work Plan (30%)** – The Consultant’s responsiveness in developing a comprehensive plan while meeting regulatory requirements and the City’s specific needs.

**Schedule (15%)** – Proposal for completing the project in a timely manner, inclusive of the Consultant’s ability to identify critical paths for the timely and competent completion of all work contemplated under the RFP.

**Cost Proposal (10%)** – The proposed compensation structure (inclusive of hourly rates of compensation, pass through costs and subconsultant costs) for the performs of the work under the RFP, inclusive of the proposed not-to-exceed amount. The proposer’s strategy for containing costs incurred by the City while meeting the objectives and standards set forth under the RFP.

**Compliance with RFP (5%)** – The ability of the Consultant to comply with all instructions set forth under this RFP as well as the Consultant’s ability to agree to all of the terms and conditions of the attached PSA without modification, particularly as relates to indemnification, insurance requirements and standards of care.

**APPENDIX C – COST PROPOSAL**

Enter below the proposed not-to-exceed amount for providing services as described in the Scope of Work.

Not to Exceed Amount: \_\_\_\_\_

Include details in the proposal to show the breakdown of the not-to exceed amount and provide hourly rate sheets as necessary.

- 1. I agree to submit monthly invoices and NET 30 payment terms.
- 2. This proposal shall remain firm for 120 days from the date of proposal.

NAME OF PROPOSER \_\_\_\_\_

ADDRESS \_\_\_\_\_

TELEPHONE \_\_\_\_\_

SIGNATURE OF PERSON  
AUTHORIZED TO BIND PROPOSER \_\_\_\_\_

NAME AND TITLE \_\_\_\_\_

DATE SIGNED \_\_\_\_\_

**ATTACHMENT 1 – STANDARD CONSULTING SERVICES AGREEMENT**  
(15 PAGES)



## ATTACHMENT 1

### CONSULTING SERVICES AGREEMENT BETWEEN THE CITY OF PINOLE AND [NAME OF CONSULTANT]

THIS AGREEMENT for consulting services is made by and between the City of Pinole ("City") and \_\_\_\_\_ ("Consultant") (together sometimes referred to as the "Parties") as of \_\_\_\_\_, 20\_\_ (the "Effective Date") in Pinole, California.

**Section 1. SERVICES.** Subject to the terms and conditions set forth in this Agreement, Consultant shall provide to City the services described in the Scope of Work attached as Exhibit A at the time and place and in the manner specified therein. In the event of a conflict in or inconsistency between the terms of this Agreement and Exhibit A, the Agreement shall prevail.

- 1.1 Term of Services.** The term of this Agreement shall begin on the Effective Date and shall end on \_\_\_\_\_, and Consultant shall complete the work described in Exhibit A by that date, unless the term of the Agreement is otherwise terminated or extended, as provided for in Section 8. The time provided to Consultant to complete the services required by this Agreement shall not affect the City's right to terminate the Agreement, as provided for in Section 8.
- 1.2 Standard of Performance.** Consultant shall perform all services required pursuant to this Agreement in the manner and according to the standards observed by a competent practitioner of the profession in which Consultant is engaged in the geographical area in which Consultant practices its profession. Consultant shall prepare all work products required by this Agreement in a professional manner and shall conform to the standards of quality normally observed by a person practicing in Consultant's profession.
- 1.3 Assignment of Personnel.** Consultant shall assign only competent personnel to perform services pursuant to this Agreement. In the event that City, in its sole discretion, at any time during the term of this Agreement, desires the reassignment of any such persons, Consultant shall, immediately upon receiving notice from City of such desire of City, reassign such person or persons.
- 1.4 Time.** Consultant shall devote such time to the performance of services pursuant to this Agreement as may be reasonably necessary to meet the standard of performance provided in Section 1.1 above and to satisfy Consultant's obligations hereunder.

**Section 2. COMPENSATION.** City hereby agrees to pay Consultant an amount not to exceed \_\_\_\_\_, for all work set forth in Exhibit A and all reimbursable expenses incurred in performing the work. In the event of a conflict between this Agreement and Consultant's proposal regarding the amount of compensation, the Agreement shall prevail. City shall pay Consultant for services rendered pursuant to this Agreement at the time and in the manner set forth herein. The payments specified below shall be the only payments from City to Consultant for services rendered pursuant to this Agreement.

Consultant shall submit all invoices to City in the manner specified herein. Except as specifically authorized by City, Consultant shall not bill City for duplicate services performed by more than one person.

Consultant and City acknowledge and agree that compensation paid by City to Consultant under this Agreement is based upon Consultant's estimated costs of providing the services required hereunder, including salaries and benefits of employees and subcontractors of Consultant. Consequently, the parties further agree that compensation hereunder is intended to include the costs of contributions to any pensions and/or annuities to which Consultant and its employees, agents, and subcontractors may be eligible. City therefore has no responsibility for such contributions beyond compensation required under this Agreement.

**2.1 Invoices.** Consultant shall submit invoices, not more often than once a month during the term of this Agreement, based on the cost for services performed and reimbursable costs incurred prior to the invoice date. Invoices shall contain the following information:

- Serial identifications of progress bills; i.e., Progress Bill No. 1 for the first invoice, etc.;
- The beginning and ending dates of the billing period;
- A Task Summary containing the original contract amount, the amount of prior billings, the total due this period, the balance available under the Agreement, and the percentage of completion;
- At City's option, for each work item in each task, a copy of the applicable time entries or time sheets shall be submitted showing the name of the person doing the work, the hours spent by each person, a brief description of the work, and each reimbursable expense;
- The total number of hours of work performed under the Agreement by Consultant and each employee, agent, and subcontractor of Consultant performing services hereunder, as well as a separate notice when the total number of hours of work by Consultant and any individual employee, agent, or subcontractor of Consultant reaches or exceeds 800 hours, which shall include an estimate of the time necessary to complete the work described in Exhibit A;
- The Consultant's signature.

**2.2 Monthly Payment.** City shall make monthly payments, based on invoices received, for services satisfactorily performed, and for authorized reimbursable costs incurred. City shall have 30 days from the receipt of an invoice that complies with all of the requirements above to pay Consultant.

**2.3 Final Payment.** City shall pay the last 10% of the total sum due pursuant to this Agreement within sixty (60) days after completion of the services and submittal to City of a final invoice, if all services required have been satisfactorily performed.

**2.4 Total Payment.** City shall pay for the services to be rendered by Consultant pursuant to this Agreement. City shall not pay any additional sum for any expense or cost whatsoever incurred by Consultant in rendering services pursuant to this Agreement. City shall make no payment for any extra, further, or additional service pursuant to this Agreement.

In no event shall Consultant submit any invoice for an amount in excess of the maximum amount of compensation provided above either for a task or for the entire Agreement, unless the Agreement is modified prior to the submission of such an invoice by a properly executed change order or amendment.

**2.5 Hourly Fees.** Fees for work performed by Consultant on an hourly basis shall not exceed the amounts shown on the following fee schedule attached hereto as Exhibit B.

**2.6 Reimbursable Expenses.** Reimbursable expenses are specified in Exhibit B, and shall not exceed \_\_\_\_\_ (\$\_\_\_\_\_). Expenses not listed in Exhibit B are not chargeable to City. Reimbursable expenses are included in the total amount of compensation provided under this Agreement that shall not be exceeded.

**2.7 Payment of Taxes.** Consultant is solely responsible for the payment of employment taxes incurred under this Agreement and any similar federal or state taxes.

**2.8 Payment upon Termination.** In the event that the City or Consultant terminates this Agreement pursuant to Section 8, the City shall compensate the Consultant for all outstanding costs and reimbursable expenses incurred for work satisfactorily completed as of the date of written notice of termination. Consultant shall maintain adequate logs and timesheets in order to verify costs incurred to that date.

**2.9 Authorization to Perform Services.** The Consultant is not authorized to perform any services or incur any costs whatsoever under the terms of this Agreement until receipt of authorization from the Contract Administrator.

**Section 3. FACILITIES AND EQUIPMENT.** Except as set forth herein, Consultant shall, at its sole cost and expense, provide all facilities and equipment that may be necessary to perform the services required by this Agreement. City shall make available to Consultant only the facilities and equipment listed in Exhibit C, and only under the terms and conditions set forth therein.

**Section 4. INSURANCE REQUIREMENTS.** Before beginning any services under this Agreement, Consultant, at its own cost and expense, shall procure the types and amounts of insurance specified herein and maintain that insurance throughout the term of this Agreement. The cost of such insurance shall be included in the Consultant's bid or proposal. Consultant shall be fully responsible for the acts and omissions of its subcontractors or other agents.

**4.1 Workers' Compensation.** Consultant shall, at its sole cost and expense, maintain Statutory Workers' Compensation Insurance and Employer's Liability Insurance for any and all persons employed directly or indirectly by Consultant in the amount required by applicable law. The requirement to maintain Statutory Workers' Compensation and Employer's Liability Insurance may be waived by the City upon written verification that Consultant is a sole proprietor and does not have any employees and will not have any employees during the term of this Agreement.

**4.2 Commercial General and Automobile Liability Insurance.**

**4.2.1 General requirements.** Consultant, Consultant, at its own cost and expense, shall maintain commercial general and automobile liability insurance for the term of this Agreement in an amount not less than TWO MILLION DOLLARS (\$2,000,000) per occurrence and FOUR MILLION DOLLARS (\$4,000,000) aggregate, combined single limit coverage for risks associated with the work contemplated by this Agreement.

**4.2.2 Minimum scope of coverage.** Commercial general coverage shall be at least as broad as Insurance Services Office Commercial General Liability occurrence form CG 0001 (most recent edition) covering comprehensive General Liability on an "occurrence" basis. Automobile coverage shall be at least as broad as Insurance Services Office Automobile Liability form CA 0001 (most recent edition) covering any auto (Code 1), or if Consultant has no owned autos, hired (code 8) and non-owned autos (Code 9). No endorsement shall be attached limiting the coverage.

**4.2.3 Additional requirements.** Each of the following shall be included in the insurance coverage or added as a certified endorsement to the policy:

- a. The Commercial General and Automobile Liability Insurance shall cover on an occurrence basis.
- b. City, its officers, officials, employees, agents, and volunteers shall be covered as additional insureds for liability arising out of work or operations on behalf of the Consultant, including materials, parts, or equipment furnished in connection with such work or operations; or automobiles owned, leased, hired, or borrowed by the Consultant. Coverage can be provided in the form of an endorsement to the Consultant's insurance at least as broad as CG 20 10 11 85, or both CG 20 10 10 01 and CG 20 37 10 01.
- c. For any claims related to this Agreement or the work hereunder, the Consultant's insurance covered shall be primary insurance as respects the City, its officers, officials, employees, agents, and volunteers. Any insurance or self-insurance maintained by the City, its officers, officials, employees, agents or volunteers shall be excess of the Consultant's insurance and non-contributing.
- d. The policy shall cover inter-insured suits and include a "separation of Insureds" or "severability" clause which treats each insured separately.
- e. Consultant agrees to give at least 30 days prior written notice to City before coverage is canceled or modified as to scope or amount.

#### **4.3 Professional Liability Insurance.**

**4.3.1 General requirements.** Consultant, at its own cost and expense, shall maintain for the period covered by this Agreement professional liability insurance for licensed professionals performing work pursuant to this Agreement in an amount not less than ONE MILLION DOLLARS (\$1,000,000) per occurrence or claim covering the Consultant's errors and omissions.

**4.3.2 Claims-made limitations.** The following provisions shall apply if the professional liability coverage is written on a claims-made form:

- a. The retroactive date of the policy must be shown and must be before the date of the Agreement.

- b. Insurance must be maintained and evidence of insurance must be provided for at least five (5) years after completion of the Agreement or the work.
- c. If coverage is canceled or not renewed and it is not replaced with another claims-made policy form with a retroactive date that precedes the date of this Agreement, Consultant must provide extended reporting coverage for a minimum of five (5) years after completion of work under this Agreement.
- d. A copy of the claim reporting requirements must be submitted to the City prior to the commencement of any work under this Agreement.

#### **4.4 All Policies Requirements.**

**4.4.1 Submittal Requirements.** Consultant shall submit the following to City prior to beginning services:

- a. Certificate of Liability Insurance in the amounts specified in this Agreement; and
- b. Additional Insured Endorsement as required for the General Commercial and Automobile Liability Policies.

**4.4.2 Acceptability of insurers.** All insurance required by this section is to be placed with insurers with a Bests' rating of no less than A:VII.

**4.4.3 Deductibles and Self-Insured Retentions.** Insurance obtained by the Consultant shall have a self-insured retention or deductible of no more than ONE HUNDRED THOUSAND DOLLARS (\$100,000).

**4.4.4 Wasting Policies.** No policy required herein shall include a "wasting" policy limit (i.e. limit that is eroded by the cost of defense).

**4.4.5 Waiver of Subrogation.** Consultant hereby agrees to waive subrogation which any insurer or contractor may require from Consultant by virtue of the payment of any loss. Consultant agrees to obtain any endorsements that may be necessary to effect this waiver of subrogation, but this provision applies regardless of whether or not the City has received a waiver of subrogation endorsement from the insurer.

**4.4.6 Subcontractors.** Consultant shall include all subcontractors as insureds under its policies or shall furnish separate certificates and endorsements for each subcontractor. All coverages for subcontractors shall be subject to all of the requirements stated herein, and Consultant shall ensure that City, its officers, officials, employees, agents, and volunteers are

covered as additional insured on all coverages.

**4.4.7 Excess Insurance.** If Consultant maintains higher insurance limits than the minimums specified herein, City shall be entitled to coverage for the higher limits maintained by the Consultant.

**4.5 Remedies.** In addition to any other remedies City may have if Consultant fails to provide or maintain any insurance policies or policy endorsements to the extent and within the time herein required, City may, at its sole option: 1) obtain such insurance and deduct and retain the amount of the premiums for such insurance from any sums due under the Agreement; 2) order Consultant to stop work under this Agreement and withhold any payment that becomes due to Consultant hereunder until Consultant demonstrates compliance with the requirements hereof; and/or 3) terminate this Agreement.

## **Section 5. INDEMNIFICATION AND CONSULTANT'S RESPONSIBILITIES.**

**5.1 General Indemnification.** To the fullest extent permitted by law, Contractor shall defend, indemnify and hold City, its officials, officers, employees, volunteers and agents free and harmless from any and all claims, demands, causes of action, costs, expenses, liability, loss, damage or injury, in law or equity, to property or persons, including wrongful death, in any manner arising out of or incident to any alleged negligent acts, omissions or willful misconduct of Contractor, its officials, officers, employees, agents, subcontractors and subcontractors arising out of or in connection with the performance of the Services, the Project or this Agreement, including without limitation the payment of all consequential damages, attorneys' fees and other related costs and expenses. Contractor shall defend, at Contractor's own cost, expense and risk, any and all such aforesaid suits, actions or other legal proceedings of every kind that may be brought or instituted against City, its directors, officials, officers, employees, agents or volunteers. Contractor shall pay and satisfy any judgment, award or decree that may be rendered against City or its directors, officials, officers, employees, agents or volunteers, in any such suit, action or other legal proceeding. Contractor shall reimburse City and its directors, officials, officers, employees, agents and/or volunteers, for any and all legal expenses and costs, including reasonable attorneys' fees, incurred by each of them in connection therewith or in enforcing the indemnity herein provided. Contractor's obligation to indemnify shall not be restricted to insurance proceeds, if any, received by City or its directors, officials, officers, employees, agents or volunteers. Notwithstanding the foregoing, to the extent Contractor's Services are subject to Civil Code Section 2782.8, the above indemnity shall be limited, to the extent required by Civil Code Section 2782.8, to

claims that arise out of, pertain to, or relate to the negligence, recklessness, or willful misconduct of the Contractor. This Section 5.1 shall survive any expiration or termination of this Agreement.

- 5.2 PERS Indemnification.** In the event that Consultant or any employee, agent, or subcontractor of Consultant providing services under this Agreement is determined by a court of competent jurisdiction or the California Public Employees Retirement System (PERS) to be eligible for enrollment in PERS as an employee of City, Consultant shall indemnify, defend, and hold harmless City for the payment of any employee and/or employer contributions for PERS benefits on behalf of Consultant or its employees, agents, or subcontractors, as well as for the payment of any penalties and interest on such contributions, which would otherwise be the responsibility of City.

## **Section 6. STATUS OF CONSULTANT.**

- 6.1 Independent Contractor.** At all times during the term of this Agreement, Consultant shall be an independent contractor and shall not be an employee of City. City shall have the right to control Consultant only insofar as the results of Consultant's services rendered pursuant to this Agreement and assignment of personnel pursuant to Subparagraph 1.3; however, otherwise City shall not have the right to control the means by which Consultant accomplishes services rendered pursuant to this Agreement. Notwithstanding any other City, state, or federal policy, rule, regulation, law, or ordinance to the contrary, Consultant and any of its employees, agents, and subcontractors providing services under this Agreement shall not qualify for or become entitled to, and hereby agree to waive any and all claims to, any compensation, benefit, or any incident of employment by City, including but not limited to eligibility to enroll in the California Public Employees Retirement System (PERS) as an employee of City and entitlement to any contribution to be paid by City for employer contributions and/or employee contributions for PERS benefits.
- 6.2 Consultant No Agent.** Except as City may specify in writing, Consultant shall have no authority, express or implied, to act on behalf of City in any capacity whatsoever as an agent. Consultant shall have no authority, express or implied, pursuant to this Agreement to bind City to any obligation whatsoever.

## **Section 7. LEGAL REQUIREMENTS.**

- 7.1 Governing Law.** The laws of the State of California shall govern this Agreement.



- 7.2 **Compliance with Applicable Laws.** Consultant and any subcontractors shall comply with all laws applicable to the performance of the work hereunder.
- 7.3 **Other Governmental Regulations.** To the extent that this Agreement may be funded by fiscal assistance from another governmental entity, Consultant and any subcontractors shall comply with all applicable rules and regulations to which City is bound by the terms of such fiscal assistance program.
- 7.4 **Licenses and Permits.** Consultant represents and warrants to City that Consultant and its employees, agents, and any subcontractors have all licenses, permits, qualifications, and approvals of whatsoever nature that are legally required to practice their respective professions. Consultant represents and warrants to City that Consultant and its employees, agents, any subcontractors shall, at their sole cost and expense, keep in effect at all times during the term of this Agreement any licenses, permits, and approvals that are legally required to practice their respective professions. In addition to the foregoing, Consultant and any subcontractors shall obtain and maintain during the term of this Agreement valid Business Licenses from City.
- 7.5 **Pinole Business License.** Consultant shall obtain a City of Pinole business license according to the terms of Title 5 of the City of Pinole Municipal Code and deliver to City proof of such business license prior to beginning work under this Agreement. Work under this Agreement cannot begin until the City receives proof that Consultant has obtained a City of Pinole business license.
- 7.6 **Nondiscrimination and Equal Opportunity.** Consultant shall not discriminate, on the basis of a person's race, religion, color, national origin, age, physical or mental handicap or disability, medical condition, marital status, sex, or sexual orientation, against any employee, applicant for employment, subcontractor, bidder for a subcontract, or participant in, recipient of, or applicant for any services or programs provided by Consultant under this Agreement. Consultant shall comply with all applicable federal, state, and local laws, policies, rules, and requirements related to equal opportunity and nondiscrimination in employment, contracting, and the provision of any services that are the subject of this Agreement, including but not limited to the satisfaction of any positive obligations required of Consultant thereby.

Consultant shall include the provisions of this Subsection in any subcontract approved by the Contract Administrator or this Agreement.

## Section 8. TERMINATION AND MODIFICATION.

- 8.1 Termination.** City may cancel this Agreement at any time and without cause upon written notification to Consultant.

In the event of termination, Consultant shall be entitled to compensation for services performed to the effective date of termination; City, however, may condition payment of such compensation upon Consultant delivering to City any or all documents, photographs, computer software, video and audio tapes, and other materials provided to Consultant or prepared by or for Consultant or the City in connection with this Agreement.

- 8.2 Extension.** City may, in its sole and exclusive discretion, extend the end date of this Agreement beyond that provided for in Subsection 1.1. Any such extension shall be specified in writing by the City. Consultant understands and agrees that if City issues such an extension, City shall have no obligation to provide Consultant with compensation beyond the maximum amount provided for in this Agreement. Similarly, unless authorized by the City, City shall have no obligation to reimburse Consultant for any otherwise reimbursable expenses incurred during the extension period.

- 8.3 Amendments.** The parties may amend this Agreement only by a writing signed by all the parties.

- 8.4 Assignment and Subcontracting.** City and Consultant recognize and agree that this Agreement contemplates personal performance by Consultant and is based upon a determination of Consultant's unique professional competence, experience, and specialized professional knowledge. Moreover, a substantial inducement to City for entering into this Agreement was and is the personal reputation and competence of Consultant. Consultant may not assign this Agreement or any interest therein without the prior written approval of the City. Consultant shall not subcontract any portion of the performance contemplated and provided for herein, other than to the subcontractors noted in the proposal, without prior written approval of the City.

- 8.5 Survival.** All obligations arising prior to the termination of this Agreement and all provisions of this Agreement allocating liability between City and Consultant shall survive the termination of this Agreement.

- 8.6 Options upon Breach by Consultant.** If Consultant materially breaches any of the terms of this Agreement, City's remedies shall include, but not be limited to, the following:

- 8.6.1 Immediately terminate the Agreement;
- 8.6.2 Retain the plans, specifications, drawings, reports, design documents, and any other work product prepared by Consultant pursuant to this Agreement;
- 8.6.3 Retain a different consultant to complete the work described in Exhibit A not finished by Consultant; or
- 8.6.4 Charge Consultant the difference between the cost to complete the work described in Exhibit A that is unfinished at the time of breach and the amount that City would have paid Consultant pursuant to Section 2 if Consultant had completed the work.

## **Section 9. KEEPING AND STATUS OF RECORDS.**

- 9.1 **Records Created as Part of Consultant's Performance.** All reports, data, maps, models, charts, studies, surveys, photographs, memoranda, plans, studies, specifications, records, files, or any other documents or materials, in electronic or any other form, that Consultant prepares or obtains pursuant to this Agreement and that relate to the matters covered hereunder shall be the property of the City. Consultant hereby agrees to deliver those documents to the City upon termination of the Agreement. It is understood and agreed that the documents and other materials, including but not limited to those described above, prepared pursuant to this Agreement are prepared specifically for the City and are not necessarily suitable for any future or other use. City and Consultant agree that, until final approval by City, all data, plans, specifications, reports and other documents are confidential and will not be released to third parties without prior written consent of both parties.
- 9.2 **Consultant's Books and Records.** Consultant shall maintain any and all ledgers, books of account, invoices, vouchers, canceled checks, and other records or documents evidencing or relating to charges for services or expenditures and disbursements charged to the City under this Agreement for a minimum of three (3) years, or for any longer period required by law, from the date of final payment to the Consultant to this Agreement.
- 9.3 **Inspection and Audit of Records.** Any records or documents that Section 9.2 of this Agreement requires Consultant to maintain shall be made available for inspection, audit, and/or copying at any time during regular business hours, upon oral or written request of the City. Under California Government Code Section 8546.7, if the amount of public funds expended under this Agreement exceeds

TEN THOUSAND DOLLARS (\$10,000.00), the Agreement shall be subject to the examination and audit of the State Auditor, at the request of City or as part of any audit of the City, for a period of three (3) years after final payment under the Agreement.

## **Section 10 MISCELLANEOUS PROVISIONS.**

- 10.1 Attorneys' Fees.** If a party to this Agreement brings any action, including an action for declaratory relief, to enforce or interpret the provision of this Agreement, the prevailing party shall be entitled to reasonable attorneys' fees in addition to any other relief to which that party may be entitled. The court may set such fees in the same action or in a separate action brought for that purpose.
- 10.2 Venue.** In the event that either party brings any action against the other under this Agreement, the parties agree that trial of such action shall be vested exclusively in the state courts of California in the County of Contra Costa or in the United States District Court for the Northern District of California.
- 10.3 Severability.** If a court of competent jurisdiction finds or rules that any provision of this Agreement is invalid, void, or unenforceable, the provisions of this Agreement not so adjudged shall remain in full force and effect. The invalidity in whole or in part of any provision of this Agreement shall not void or affect the validity of any other provision of this Agreement.
- 10.4 No Implied Waiver of Breach.** The waiver of any breach of a specific provision of this Agreement does not constitute a waiver of any other breach of that term or any other term of this Agreement.
- 10.5 Successors and Assigns.** The provisions of this Agreement shall inure to the benefit of and shall apply to and bind the successors and assigns of the parties.
- 10.6 Use of Recycled Products.** Consultant shall endeavor to prepare and submit all reports, written studies and other printed material on recycled paper to the extent it is available at equal or less cost than virgin paper.
- 10.7 Conflict of Interest.** Consultant may serve other clients, but none whose activities within the corporate limits of City or whose business, regardless of location, would place Consultant in a "conflict of interest," as that term is defined in the Political Reform Act, codified at California Government Code Section 81000 *et seq.*

Consultant shall not employ any City official in the work performed pursuant to this Agreement. No officer or employee of City shall have any financial interest in this Agreement that would violate California Government Code Sections 1090 *et seq.*

Consultant hereby warrants that it is not now, nor has it been in the previous twelve (12) months, an employee, agent, appointee, or official of the City. If Consultant was an employee, agent, appointee, or official of the City in the previous twelve months, Consultant warrants that it did not participate in any manner in the forming of this Agreement. Consultant understands that, if this Agreement is made in violation of Government Code §1090 *et. seq.*, the entire Agreement is void and Consultant will not be entitled to any compensation for services performed pursuant to this Agreement, including reimbursement of expenses, and Consultant will be required to reimburse the City for any sums paid to the Consultant. Consultant understands that, in addition to the foregoing, it may be subject to criminal prosecution for a violation of Government Code § 1090 and, if applicable, will be disqualified from holding public office in the State of California.

Consultant will comply with all conflict of interest laws and regulations including, without limitation, City's Conflict of Interest Code (on file in the City Clerk's Office). It is incumbent upon the Consultant or Consultant's firm to notify the City pursuant to section 10.10 Notices of any staff changes relating to this Agreement.

- a. In accomplishing the scope of services of this Agreement, all officers, employees and/or agents of Consultant(s), unless as indicated in Subsection b., will be performing a very limited and closely supervised function, and, therefore, are unlikely to have a conflict of interest arise. No disclosures are required for any officers, employees, and/or agents of Consultant, except as indicated in Subsection b.

---

Initialed by City Attorney's Office

- b. In accomplishing the scope of services of this Agreement, Consultant(s) will be performing a specialized or general service for the City, and there is substantial likelihood that the Consultant's work product will be presented, either written or orally, for the purpose of influencing a governmental decision. As a result, the following Consultant(s) shall be subject to the Disclosure Category "1-5" of the City's Conflict of Interest Code:

\_\_\_\_\_  
\_\_\_\_\_

**10.8 Solicitation.** Consultant agrees not to solicit business at any meeting, focus group, or interview related to this Agreement, either orally or through any written materials.

**10.9 Contract Administration.** This Agreement shall be administered by \_\_\_\_\_ who shall act as the City's representative. All correspondence shall be directed to or through \_\_\_\_\_ or his or her designee.

**10.10 Notices.** Any written notice to Consultant shall be sent to:

\_\_\_\_\_  
\_\_\_\_\_  
\_\_\_\_\_

Any written notice to City shall be sent to:

\_\_\_\_\_  
\_\_\_\_\_  
\_\_\_\_\_

**10.11 Professional Seal.** Where applicable in the determination of the City, the first page of a technical report, first page of design specifications, and each page of construction drawings shall be stamped/sealed and signed by the licensed professional responsible for the report/design preparation.

**10.12 Integration; Incorporation.** This Agreement, including all the exhibits attached hereto, represents the entire and integrated agreement between City and Consultant and supersedes all prior negotiations, representations, or agreements, either written or oral. All exhibits attached hereto are incorporated by reference herein.

**10.13 Counterparts.** This Agreement may be executed in multiple counterparts, each of which shall be an original and all of which together shall constitute one agreement.

The Parties have executed this Agreement as of the Effective Date.

CITY OF PINOLE

CONSULTANT

\_\_\_\_\_  
Neil Gang, Interim City Manager

\_\_\_\_\_  
**[NAME, TITLE]**

Consultant's City of Pinole Business

License #: \_

Attest:

\_\_\_\_\_  
Heather Bell, City Clerk

Approved as to Form:

\_\_\_\_\_  
Eric S. Casher, City Attorney

**ATTACHMENT 2 – PLANS**  
(6 PAGES)



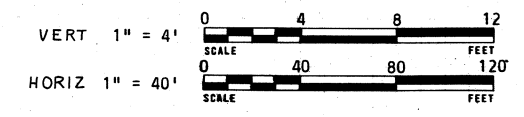
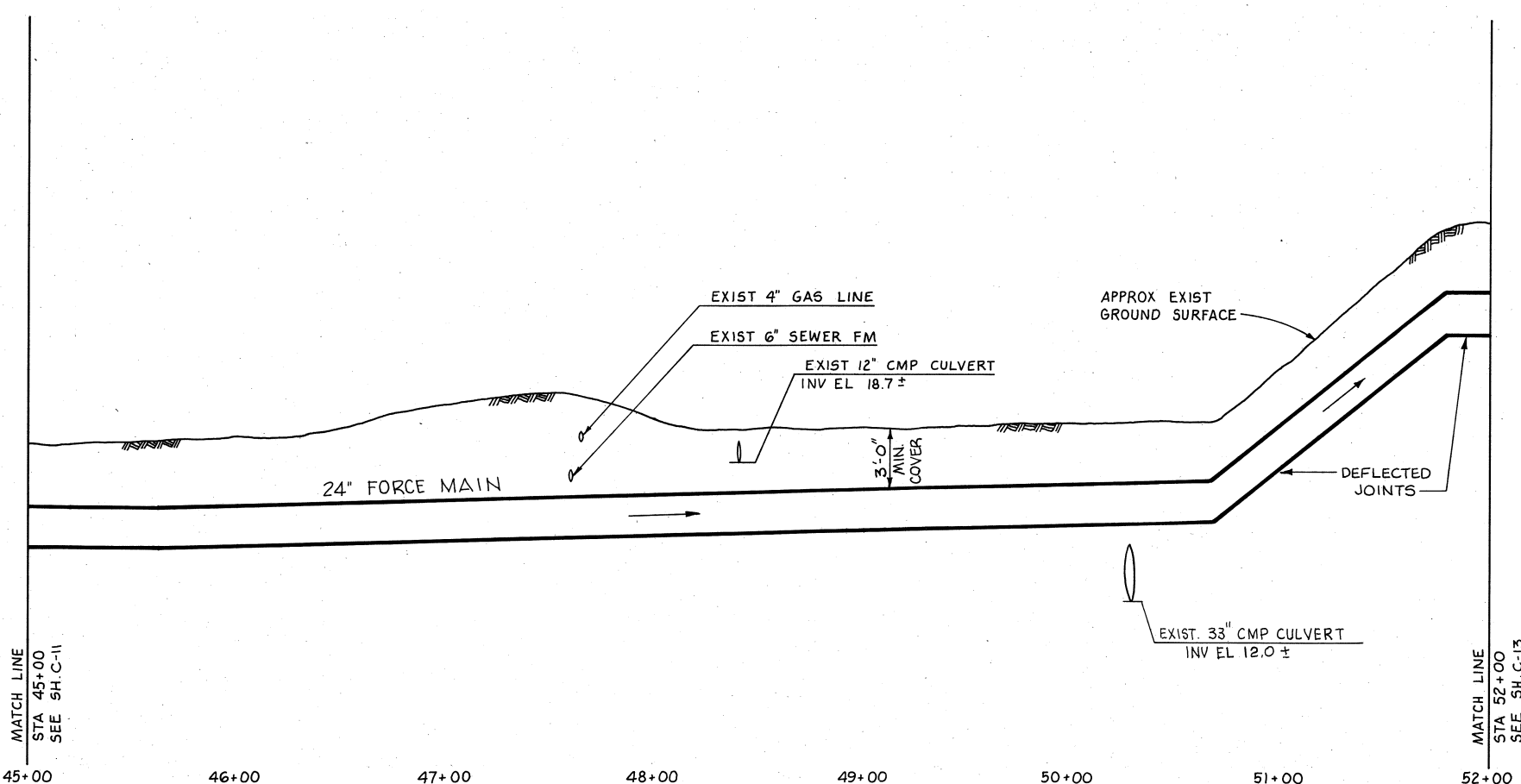



DRAWN BY  
 G.W. CORDELL  
 DEPT. CHECK  
*E. Dela Cruz*  
 PROJ. CHECK  
 APPROVED BY:  
*[Signature]*

**CITY OF PINOLE**  
 CONTRA COSTA COUNTY, CALIF.

SCALE:  
 AS SHOWN  
**HALF SCALE DRAWING**

EPA GRANT NO. C-06-1577  
 CITY OF PINOLE  
 EFFLUENT PUMPING STATION AND FORCE MAIN TO RODEO  
 CIVIL  
 PLAN AND PROFILE

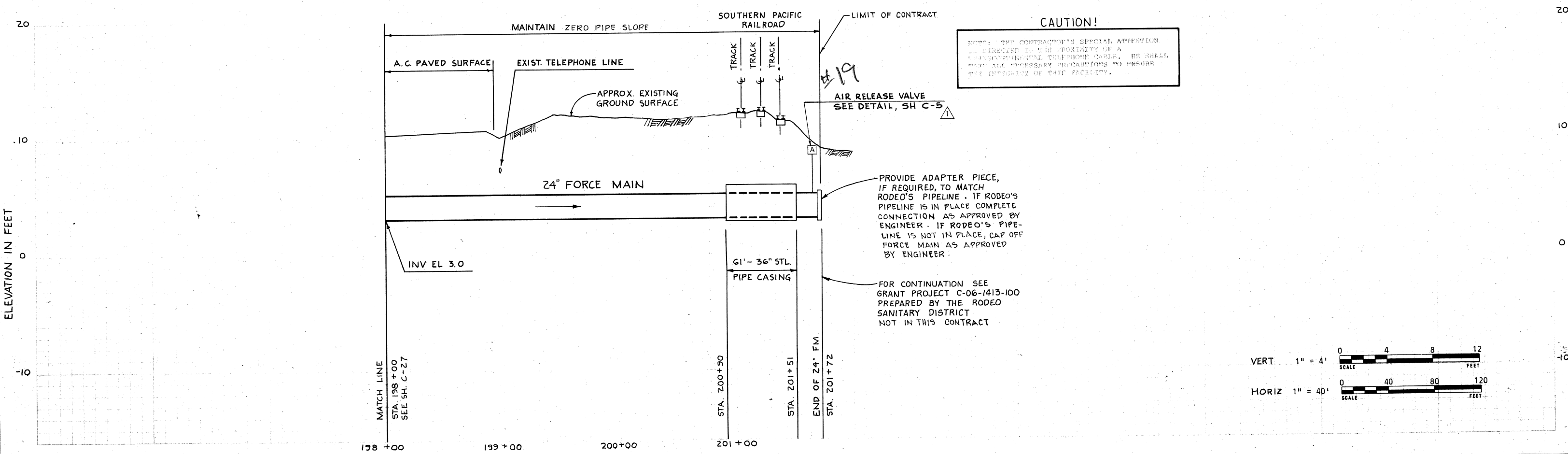
JOB: 5399.3  
 FILE NO. \_\_\_\_\_  
 C-12



**CAUTION!**  
 NOTE: THE CONTRACTOR'S SPECIAL ATTENTION IS DIRECTED TO THE PROXIMITY OF A LOW-VOLTAGE TELEPHONE CABLE. HE SHALL TAKE ALL NECESSARY PRECAUTIONS TO ENSURE THE INTEGRITY OF THIS FACILITY.

PROVIDE ADAPTER PIECE, IF REQUIRED, TO MATCH RODEO'S PIPELINE. IF RODEO'S PIPELINE IS IN PLACE COMPLETE CONNECTION AS APPROVED BY ENGINEER. IF RODEO'S PIPELINE IS NOT IN PLACE, CAP OFF FORCE MAIN AS APPROVED BY ENGINEER.

FOR CONTINUATION SEE GRANT PROJECT C-06-1413-100 PREPARED BY THE RODEO SANITARY DISTRICT NOT IN THIS CONTRACT

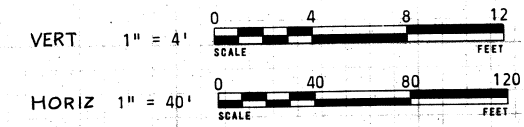

DRAWN BY <i>B. Taglietta</i>	CITY OF PINOLE CONTRA COSTA COUNTY, CALIF.	M&E METCALF & EDDY/ENGINEERS BOSTON/NEW YORK/PAID ALTO/CHICAGO	SCALE: AS SHOWN <b>HALF SCALE</b>	EPA GRANT NO. C-06-1577 CITY OF PINOLE EFFLUENT PUMPING STATION AND FORCE MAIN TO RODEO	JOB 5399.3
					FILE NO.
DEPT. CHECK <i>E. Dale Cruz</i>	APPROVED BY:			CIVIL	

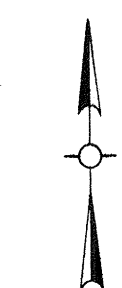
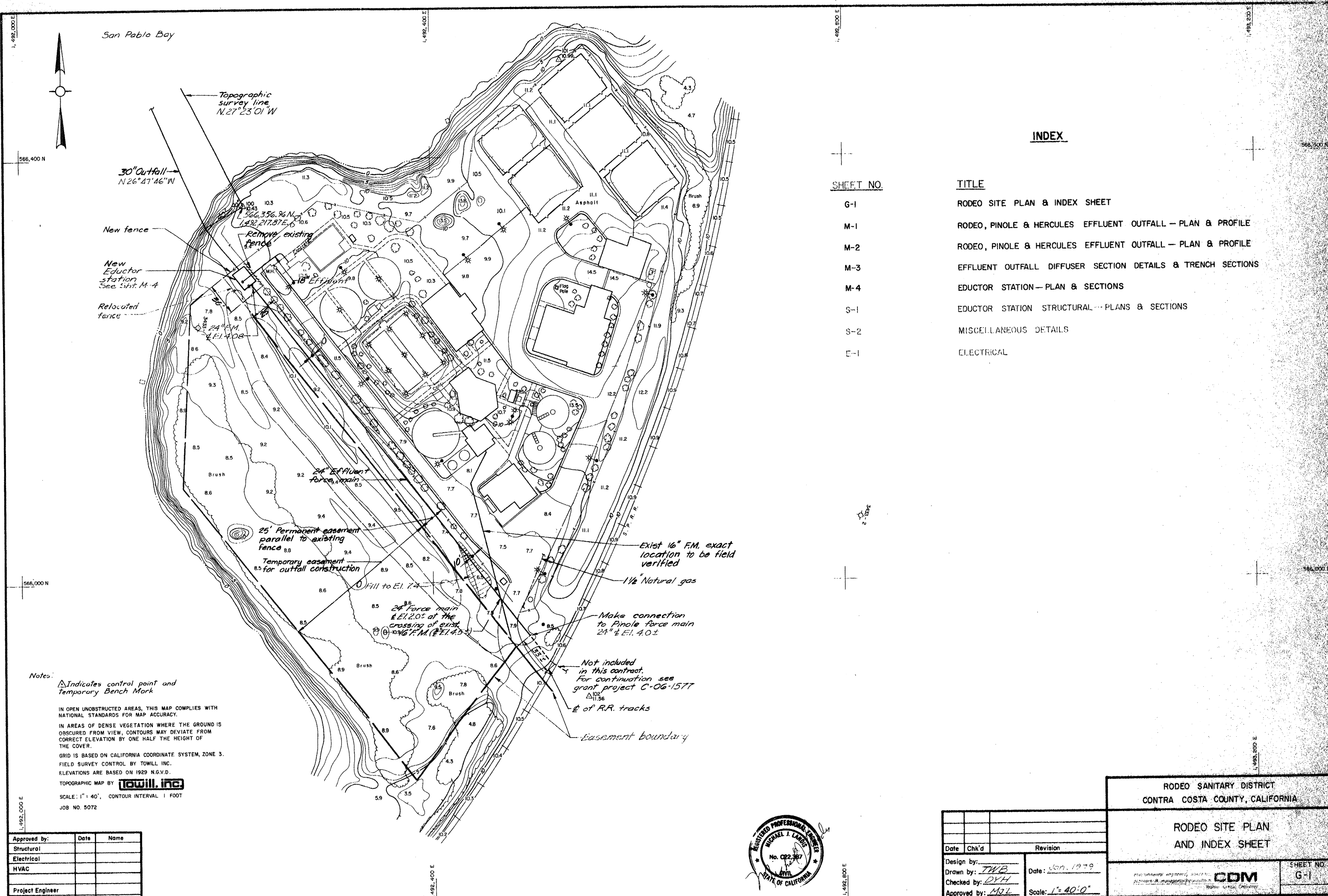

San Pablo Bay

Topographic survey line  
N.27°23'01"W

30" Outfall  
N.26°47'46"W

New fence

New Educator station  
See Sht. M-4

Relocated fence

Remove existing fence

25' Permanent easement parallel to existing fence

Temporary easement for outfall construction

24" Force main @ El. 2.05 at the crossing of exist. 16" F.M. @ El. 4.5

Exist 16" F.M. exact location to be field verified

1 1/2" Natural gas

Make connection to Pinole force main 24" @ El. 4.0 ±

Not included in this contract. For continuation see grant project C-06-1577

℄ of R.R. tracks

Easement boundary

Notes:  
△ Indicates control point and Temporary Bench Mark

IN OPEN UNOBSTRUCTED AREAS, THIS MAP COMPLIES WITH NATIONAL STANDARDS FOR MAP ACCURACY.  
IN AREAS OF DENSE VEGETATION WHERE THE GROUND IS OBSCURED FROM VIEW, CONTOURS MAY DEVIATE FROM CORRECT ELEVATION BY ONE HALF THE HEIGHT OF THE COVER.  
GRID IS BASED ON CALIFORNIA COORDINATE SYSTEM, ZONE 3. FIELD SURVEY CONTROL BY TOWILL INC. ELEVATIONS ARE BASED ON 1929 N.G.V.D.  
TOPOGRAPHIC MAP BY **Towill, Inc.**  
SCALE: 1" = 40', CONTOUR INTERVAL 1 FOOT  
JOB NO. 5072

Approved by:	Date	Name
Structural		
Electrical		
HVAC		
Project Engineer		
Project Manager		



**INDEX**

**SHEET NO.**

- G-1
- M-1
- M-2
- M-3
- M-4
- S-1
- S-2
- E-1

**TITLE**

- RODEO SITE PLAN & INDEX SHEET
- RODEO, PINOLE & HERCULES EFFLUENT OUTFALL — PLAN & PROFILE
- RODEO, PINOLE & HERCULES EFFLUENT OUTFALL — PLAN & PROFILE
- EFFLUENT OUTFALL DIFFUSER SECTION DETAILS & TRENCH SECTIONS
- EDUCTOR STATION — PLAN & SECTIONS
- EDUCTOR STATION STRUCTURAL — PLANS & SECTIONS
- MISCELLANEOUS DETAILS
- ELECTRICAL

Date	Chk'd	Revision
Design by:		
Drawn by: <i>TWB</i>		Date: 10-19-79
Checked by: <i>DYH</i>		Scale: 1" = 40'-0"
Approved by: <i>MJL</i>		

RODEO SANITARY DISTRICT  
CONTRA COSTA COUNTY, CALIFORNIA

**RODEO SITE PLAN  
AND INDEX SHEET**

SHEET NO.  
G-1

**CDM**  
CONSTRUCTION DOCUMENTS  
MANAGEMENT

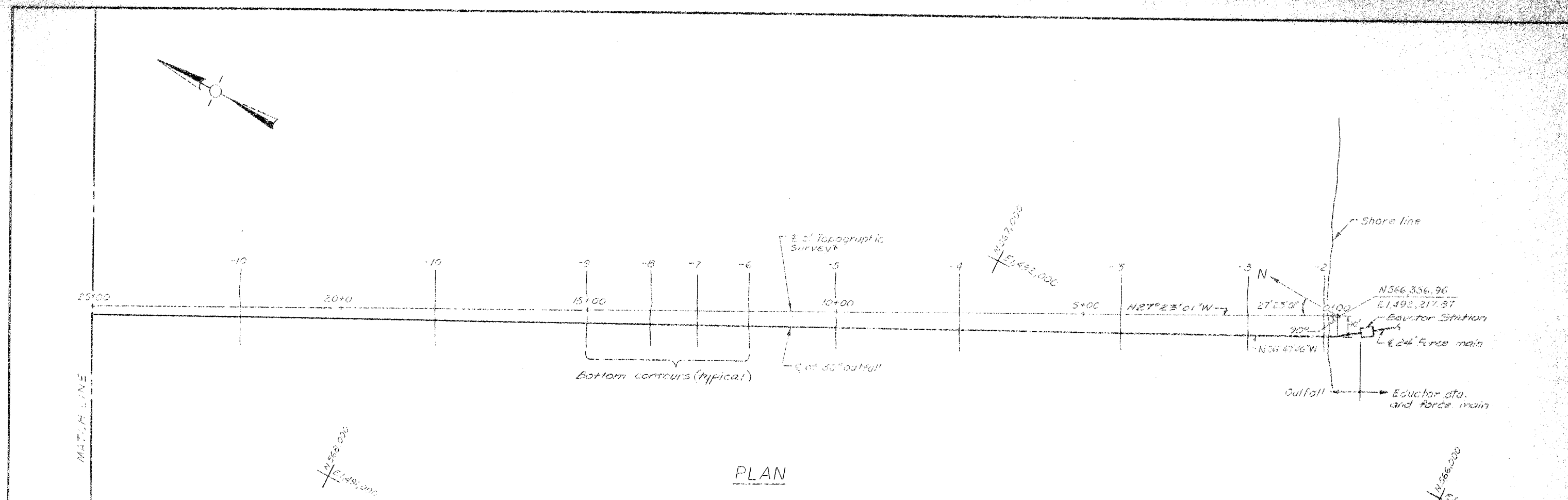

PLAN



PROFILE

Note: \* Refer to Geotechnical Investigation Report by Conversa Davis Dixon Associates



Approved by:	Date	Name
Structural		
Electrical		
HVAC		
Project Engineer		
Project Manager		

Date	Chk'd	Revision

Design by: *RYH*  
 Drawn by: *RLT*  
 Checked by: *RYH*  
 Approved by: *NTZ*

Date: *Jan. 1979*  
 Scale: *HORIZ. 1"=100'*  
*VERT. 1"=5'*

RODEO SANITARY DISTRICT  
 CONTRA COSTA COUNTY, CALIFORNIA

**RODEO, PINOLE AND HERCULE'S  
 EFFLUENT OUTFALL  
 PLAN & PROFILE**

CONTRACT NO. 1978-01  
 PROJECT NO. 1978-01

**CDM**  
 CONSULTING ENGINEERS, SCIENTISTS,  
 ARCHITECTS & PLANNERS  
 10000 Wilshire Blvd., Suite 1000  
 Los Angeles, California 90024  
 Phone: (213) 749-1000

SHEET NO.  
**M-1**

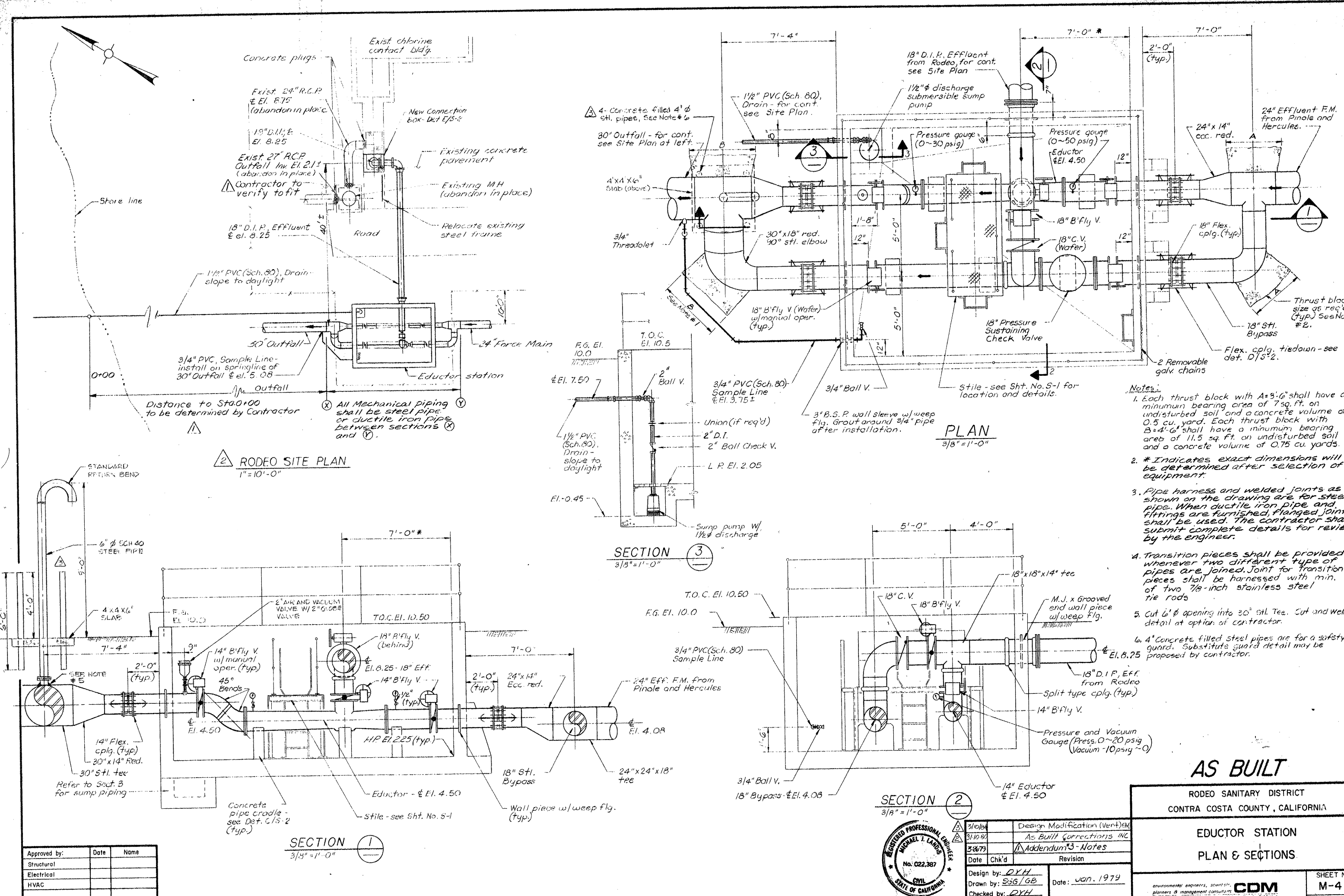

**2 RODEO SITE PLAN**  
1" = 10'-0"

**SECTION 3**  
3/8" = 1'-0"

**SECTION 2**  
3/8" = 1'-0"

**PLAN**  
3/8" = 1'-0"

- Notes:**
1. Each thrust block with A=5'-6" shall have a minimum bearing area of 7 sq. ft. on undisturbed soil and a concrete volume of 0.5 cu. yard. Each thrust block with B=4'-6" shall have a minimum bearing area of 11.5 sq. ft. on undisturbed soil and a concrete volume of 0.75 cu. yards.
  2. \* Indicates exact dimensions will be determined after selection of equipment.
  3. Pipe harness and welded joints as shown on the drawing are for steel pipe. When ductile iron pipe and fittings are furnished, flanged joints shall be used. The contractor shall submit complete details for review by the engineer.
  4. Transition pieces shall be provided whenever two different type of pipes are joined. Joint for transition pieces shall be harnessed with min. of two 7/8-inch stainless steel tie rods.
  5. Cut 6"  $\phi$  opening into 30" stl. Tee. Cut and weld detail at option of contractor.
  6. 4" concrete filled steel pipes are for a safety guard. Substitute guard detail may be proposed by contractor.

**AS BUILT**

RODEO SANITARY DISTRICT CONTRA COSTA COUNTY, CALIFORNIA	
<b>EDUCATOR STATION PLAN &amp; SECTIONS</b>	
SHEET NO. <b>M-4</b>	

Approved by:	Date	Name
Structural		
Electrical		
HVAC		
Project Engineer		
Project Manager		

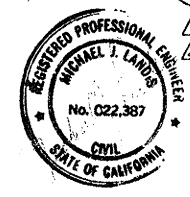

3/10/84	Design Modification (Vert) SM	
3/10/84	As Built corrections MC	
3-26-79	Addendum 3-Notes	
Date	Chk'd	Revision
Design by: <b>DYH</b>	Date: <b>Jan. 1979</b>	
Drawn by: <b>SJS/GB</b>		
Checked by: <b>DYH</b>		
Approved by: <b>MJL</b>	Scale: <b>AS NOTED</b>	

environmental engineers, soil scientists  
planners & management consultants  
**CDM**  
Walnut Creek, California

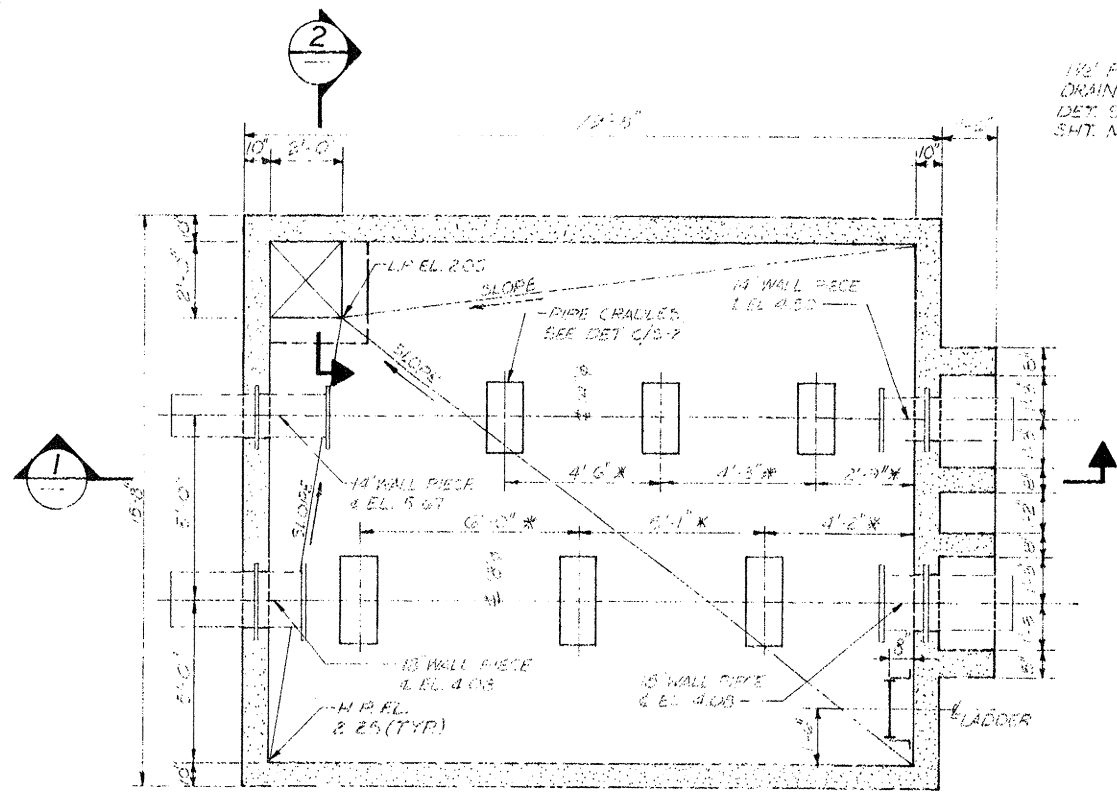

**BOTTOM PLAN**  
3/8"=1'-0"

1/2" PVC (SCH 40)  
DRAIN @ EL. 7.50 FOR  
DET. SEE SECTION 3  
SHT. A1-4

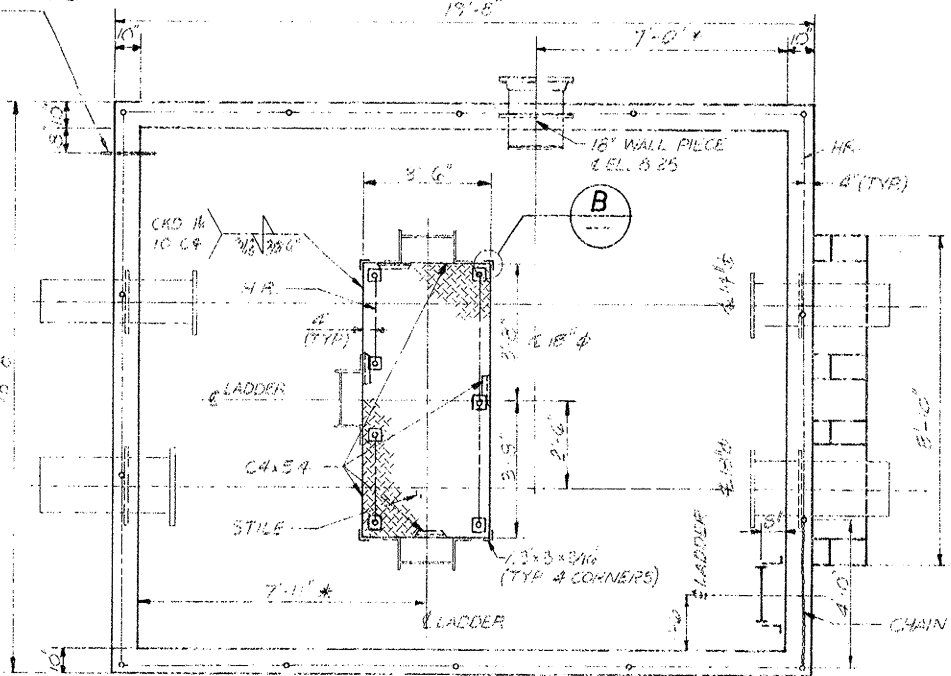

**TOP PLAN**  
3/8"=1'-0"

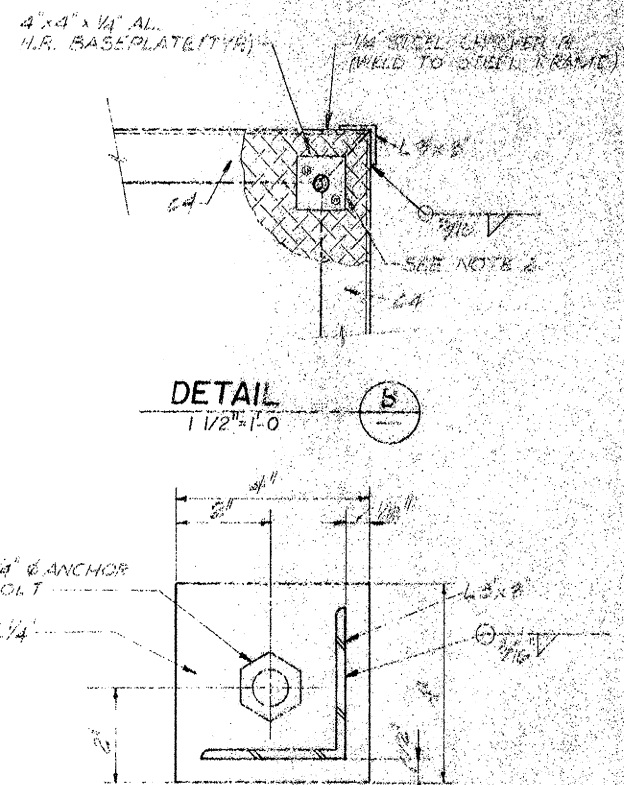

**DETAIL B**  
1/2"=1'-0"

**NOTE:** \* EXACT DIMENSIONS TO BE FIELD  
VERIFIED AFTER SELECTION OF  
EQUIPMENT

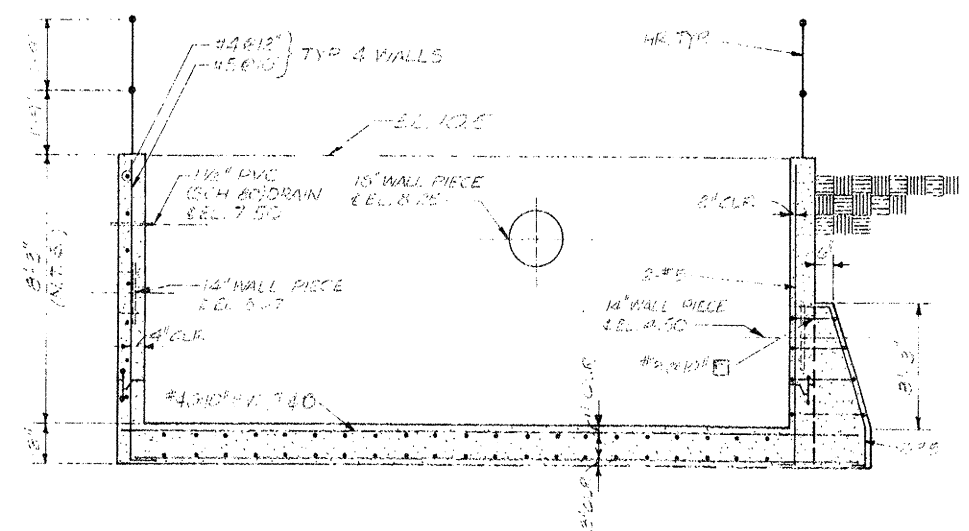

**SECTION 1**  
3/8"=1'-0"

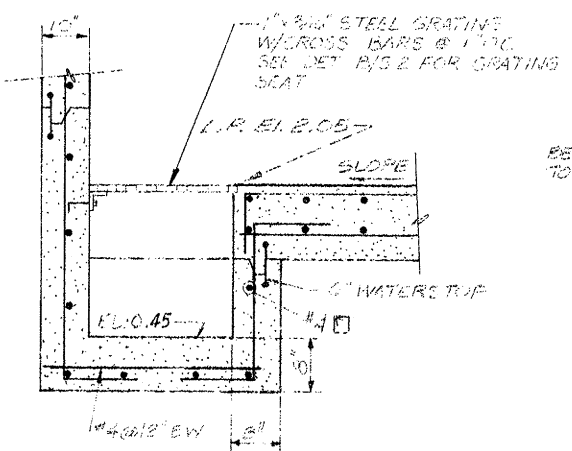

**SECTION 2**  
3/4"=1'-0"

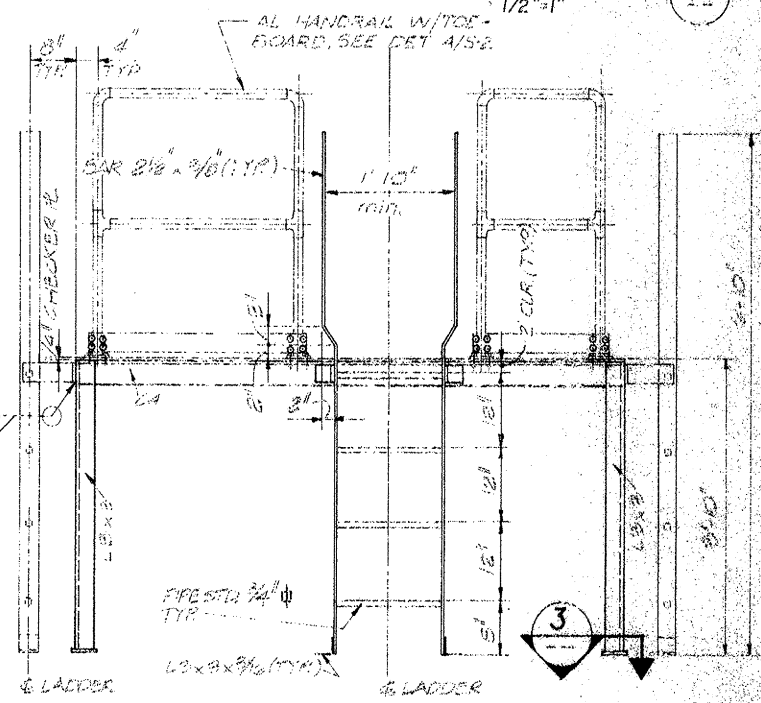

**STILE ELEVATION**  
3/4"=1'-0"

**NOTES:**  
1. STILE SHALL BE WELDED  
CONSTRUCTION.  
2. NEARBY WALL SHALL  
BE USED RETAINING  
ALL HANDRAIL BRACKETS,  
PLATES AND STILE  
CHECKERPLATE.

Approved by:	Date:	Name:
Structural		
Electrical		
HVAC		
Project Engineer		
Project Manager		



Date	Chk'd	Revision

Design by: ES  
 Drawn by: KMS  
 Checked by: [Signature]  
 Approved by: [Signature]

Date: Jan. 1978  
 Scale: AS NOTED

RODEO SANITARY DISTRICT  
 CONTRA COSTA COUNTY, CALIFORNIA

**EDUCTOR STATION  
 STRUCTURAL  
 PLANS AND SECTIONS**

environmental engineers, architects,  
 planning & management consultants  
**CDM**  
 1000 14th St., Suite 1000  
 Berkeley, CA 94710

SHEET NO.  
**S-1**

**ATTACHMENT 3 – LINKS TO PERMITS, JPA**  
(20 PAGES)

**LINKS TO PERMITS**

Pinole-Hercules R2-2023-0008:

[https://www.waterboards.ca.gov/sanfranciscobay/board\\_decisions/adopted\\_orders/2023/R2-2023-0008.pdf](https://www.waterboards.ca.gov/sanfranciscobay/board_decisions/adopted_orders/2023/R2-2023-0008.pdf)

Rodeo Sanitary District R2-2022-0037:

[https://www.waterboards.ca.gov/sanfranciscobay/board\\_decisions/adopted\\_orders/2022/R2-2022-0037.pdf](https://www.waterboards.ca.gov/sanfranciscobay/board_decisions/adopted_orders/2022/R2-2022-0037.pdf)

**JPA**

(attached)



JOINT EXERCISE OF POWERS AGREEMENT

THIS AGREEMENT dated this 16 day of August, 1977, is made and entered into by and between the CITY OF PINOLE, a municipal corporation, hereinafter called "Pinole", the CITY OF HERCULES, a municipal corporation, hereinafter called "Hercules", and the RODEO SANITARY DISTRICT, a public district created pursuant to the laws of the State of California hereinafter called "Rodeo".

RECITALS:

Title 1, Division 7, Chapter 5, of the Government Code of the State of California (Sections 6500, et seq.) authorizes two or more public agencies by agreement to exercise any power common to the contracting parties.

Pinole, Hercules, and Rodeo possess in common the power to collect, treat, and dispose of wastewater.

Pinole owns and operates a plant for the treatment of wastewater collected from both Pinole and Hercules, said plant hereinafter referred to as the "Pinole Plant".

Rodeo owns and operates a plant for the treatment of wastewater, collected from Rodeo Sanitary District, hereinafter referred to as the "Rodeo Plant".

In order to comply with the requirements of the California Regional Water Quality Control Board, San Francisco Bay Region, with respect to discharge of treated wastewater from both the Pinole Plant and the Rodeo Plant into San Pablo Bay, the three

agencies propose to provide deepwater joint wastewater disposal facilities consisting of a deepwater outfall and associated on-shore facilities (hereinafter called "disposal facilities).

All parties desire to provide disposal facilities for present treated wastewater flows and for anticipated future flows of treated wastewater within each party's service area.

It appears in the best interests of the parties to provide one joint wastewater disposal system which will be used for the disposal of treated wastewater from both the Pinole Plant and the Rodeo Plant.

It is the desire and intent of the parties hereto, without in any way surrendering the sovereignty of their respective governmental authority, to enter into an agreement whereby treated wastewater disposal facilities will be constructed, maintained and operated by Rodeo for the mutual benefit of Pinole, Hercules and Rodeo. Payment for such construction, maintenance and operation shall be made as specified herein.

Pinole, Hercules and Rodeo desire to set forth in this Agreement the basis for the sizing of disposal facilities, flow allocations, the sharing of design, construction, operation, maintenance costs and other related matters.

To carry out the intentions of the parties, it will be necessary to construct, maintain and operate a treated wastewater transmission pipeline from the Pinole Plant to an agreed upon connection point with the deepwater outfall. Said pipeline and connection point are hereinafter referred to as the Pinole-Hercules Transmission System. Rodeo shall not be involved

in the construction, maintenance or operation of the Pinole-Hercules Transmission System except as specifically provided herein.

NOW, THEREFORE, FOR AND IN CONSIDERATION OF THE MUTUAL PROMISES HEREIN CONTAINED, THE PARTIES HERETO AGREE AS FOLLOWS:

1. Recitals. The recitals hereinabove set forth are included herein and made a part of this Agreement.

2. Delivery of Treated Wastewater. Pinole shall deliver to Rodeo all wastewater treated at the Pinole Plant. However, in the event a wastewater reclamation system is implemented using treated wastewater from the Pinole Plant, Pinole may reduce the quantity of treated wastewater delivered to Rodeo by the amount of such wastewater reclaimed.

3. Disposal Facilities and Acceptance for Disposal. Rodeo shall construct, operate and maintain disposal facilities for the anticipated flow of treated wastewater delivered from the Pinole Plant and Rodeo Plant. Rodeo shall accept for deep-water disposal the treated wastewater as delivered by Pinole in accordance with the terms and conditions herein contained.

4. Wastewater Reclamation. In the event a wastewater reclamation system is implemented or authorized by Rodeo using the treated wastewater from both the Pinole Plant and the Rodeo Plant, Rodeo may reduce the quantity of treated wastewater discharged into the Bay by such wastewater reclaimed. In the event that such reclaimed wastewater is sold, the parties hereto shall share in the net proceeds of such sale in proportion to the amount of wastewater contributed by the respective agencies.

Net proceeds for purposes of this section is the amount remaining after payment for reclamation costs.

Before distribution of such net proceeds there shall be deducted therefrom any costs of maintenance and operation of the disposal facilities which have not been paid by the party to whom such distribution of net proceeds is to be made.

5. Federal and State Assistance. Rodeo shall file or cause to have filed the necessary applications for grants of Federal and State funds which are or may be available for construction of disposal facilities, and undertake all proceedings necessary to secure such funds for the benefit of all three parties hereto. Pinole and Hercules will in this regard cooperate fully with Rodeo by furnishing all information and material available to them that is required to obtain such Federal and State funds.

6. Pinole-Hercules Transmission System. Pinole and Hercules shall construct, operate, maintain and jointly own the Pinole-Hercules Transmission System from the Pinole Plant to a connection point with the disposal facilities. Appropriate plans and diagrams of said connection point are attached hereto as Exhibit A and included herein by this reference. Rodeo hereby consents to Pinole and Hercules constructing, operating and maintaining said Pinole-Hercules Transmission System within the boundaries of Rodeo. The cost of acquisition, if any, of property needed for the Pinole-Hercules Transmission System shall be borne by Pinole and Hercules as follows:

Pinole's share of said cost shall be:

$$\frac{\text{Pinole's design peak hourly wet weather flow in said transmission system}}{\text{Total design peak hourly wet weather flow in said transmission system}}$$

and Hercules share of said cost shall be:

$$\frac{\text{Hercules' design peak hourly wet weather flow in said transmission system}}{\text{Total design peak hourly wet weather flow in said transmission system}}$$

The design and construction costs of the Pinole-Hercules Transmission System shall be borne by Pinole and Hercules in the following manner:

A = Total cost for design (or construction) of Transmission System

Pinole's share of the design (or construction) cost shall be:

$$A \times \frac{\text{Pinole's design peak hourly wet weather flow in said transmission system}}{\text{Total design peak hourly wet weather flow in said transmission system}}$$

and Hercules' share of said cost shall be:

$$A \times \frac{\text{Hercules' design peak hourly wet weather flow in said transmission system}}{\text{Total design peak hourly wet weather flow in said transmission system}}$$

Costs of operation and maintenance of the Pinole-Hercules Transmission System shall be borne by Pinole and Hercules as follows:

Pinole:

$$\frac{\text{Pinole's actual annual flow in said transmission system}}{\text{Total actual annual flow in said transmission system}}$$

Hercules:

Hercules' actual annual flow in said transmission  
system  

---

Total actual annual flow in said transmission  
system

The sharing of costs between Pinole and Hercules as described in this paragraph is absolute without regard to the source of funds used to pay such costs. Pinole is authorized to file the necessary applications for grants of Federal and State funds which are or may be available for construction of the Pinole-Hercules Transmission System, and undertake all proceedings necessary to secure such funds for the benefit of Pinole and Hercules. If such grants supply greater funds to Pinole than is calculated to be the Pinole share from the above formula for design and construction costs, Pinole shall pay to Hercules any portion of such grants which exceed the Pinole share.

Fifty (50%) percent of Hercules' share of estimated costs of design shall be paid by Hercules to Pinole within sixty (60) days after execution of this Agreement, and the remaining fifty (50%) percent of such estimated costs shall be paid by Hercules to Pinole upon approval of project plans and specifications by the staff of the State Water Resources Control Board. Reconciliation of estimated design costs with actual design costs shall be made by Pinole within sixty (60) days following Pinole's receipt of final Step 2 grant payment. Additional payment to Pinole or reimbursement by Pinole, as the case may be, shall be made within said sixty (60) day period.

Hercules shall contribute its full share of the estimated construction costs to Pinole prior to commencement of construction work. Reconciliation of estimated local construction costs with

actual local construction costs shall be made by Pinole within sixty (60) days following Pinole's receipt of final Step 3 grant payment. Any additional payment to Pinole or reimbursement by Pinole, as the case may be, shall be made within said sixty (60) day period.

Upon completion of construction, Pinole shall bill Hercules for its share of the cash flow interest expense. Hercules shall make such payment within thirty (30) days.

Once the transmission system is placed into operation Pinole shall begin accounting for flows and costs associated with the system. Pinole shall bill Hercules within sixty (60) days after the end of each fiscal year and shall use actual costs incurred and actual flows contributed during the course of the year. Hercules shall make its payment to Pinole within thirty (30) days after receipt of the bill from Pinole.

7. Wastewater Flow Measurement. Pinole shall install, operate and maintain flow measuring and recording devices for continuously measuring and recording the total treated wastewater flow delivered to the disposal facilities. The cost for installation, operation and maintenance of such devices shall be shared by Pinole and Hercules based upon the respective pro-rata flow attributed to Pinole and Hercules respectively. There is in existence a separate measuring and recording device to measure and record Hercules' flow of wastewater to the Pinole Plant.

8. Pro-Ration of Local Capital Costs. Local capital costs

are those design and construction costs not paid by Federal and State grant assistance. Costs for design include actual engineering design and work associated with design which directly relates to the preparation of construction plans and specifications, the bidding of contractors on the work, the acquisition of required permits and authorizations to proceed with construction, preparation of operation and maintenance manuals, revenue program requirements, and wastewater discharge studies. Costs for construction shall include contractor costs, construction supervision costs, and legal and administrative expenses.

Local capital costs shall be shared on the basis of each agency's allocated peak hourly wet weather flow (see Exhibit B) and a factor to take into account the potentially different Federal and State grant eligibility associated with each party.

The local capital costs for design and construction will be shared as follows: Subscripts "P", "H", and "R" refer to Pinole, Hercules, and Rodeo, respectively.

A = Total local cost for design or construction of disposal facilities

B = Agency's appropriate flow allocation (see Exhibit B)

C = Agency's Federal and State grant eligibility for purposes of this paragraph shall be:

Agency's Federal and State grant eligible flow  
Agency's flow allocation from Exhibit B

(Note: Value for "C" cannot be greater than 1.00)

E = Fraction of Federal and State grant on eligible facilities



F = Agency's eligibility factor shall be:  $1 - C \times E$

$$\text{Pinole cost} = A \times \left( \frac{(B_P \times F_P)}{(B_P \times F_P) + (B_H \times F_H) + (B_R \times F_R)} \right)$$

$$\text{Hercules cost} = A \times \left( \frac{(B_H \times F_H)}{(B_P \times F_P) + (B_H \times F_H) + (B_R \times F_R)} \right)$$

$$\text{Rodeo cost} = A \times \left( \frac{(B_D \times F_D)}{(B_P \times F_P) + (B_H \times F_H) + (B_R \times F_R)} \right)$$

Fifty percent of estimated local costs of design for Pinole and Hercules shall be paid by Pinole and Hercules to Rodeo within 60 days after execution of this Agreement, and the remaining 50 percent of such estimated costs shall be paid by Pinole and Hercules to Rodeo upon approval of project plans and specifications by the staff of the State Water Resources Control Board. Reconciliation of estimated costs with actual costs shall be made by Rodeo within 60 days following Rodeo's receipt of final Step 2 grant payment. Additional payment to Rodeo or reimbursement by Rodeo, as the case may be, shall be made within said sixty (60) day period.

Pinole and Hercules shall contribute their full share of the estimated construction cost of the disposal facilities to District prior to commencement of construction work. Reconciliation of estimated local construction costs with actual local construction costs shall be made by Rodeo within 60 days following Rodeo's receipt of final Step 3 grant payment. Additional payment to Rodeo or reimbursement by Rodeo, as the case may be, shall be made within said sixty (60) day period.

9. Pro-Ration of Operation and Maintenance Costs. The parties hereto agree that operation and maintenance costs will

be shared on the basis of volumes of treated wastewater delivered to the disposal facilities.

H = total operation and maintenance costs of the disposal facilities during the fiscal year.

I = fraction of flow from Pinole and Hercules:

$$\frac{\text{Total flow delivered by Pinole during fiscal year}}{\text{Total flow through disposal facilities during fiscal year}}$$

J = amount charged to Pinole for each fiscal year:

$$J = H \times I$$

K = fraction of flow from Hercules:

$$\frac{\text{Total flow delivered by Hercules to Pinole Plant during fiscal year}}{\text{Total flow through Pinole Plant during fiscal year}}$$

L = amount charged to Hercules for each fiscal year

$$L = J \times K$$

The net amount to be paid by Pinole is  $J - L$ .

Once Pinole begins delivering treated wastewater to the disposal facilities, Rodeo shall begin accounting for flows and costs associated with said facilities. Rodeo shall annually estimate the costs of operation and maintenance of the disposal facilities and shall bill Pinole at the beginning of each fiscal year for a share of such costs based upon estimated flows from the Pinole Plant. Upon receipt of such bill, Pinole shall bill Hercules for its estimated share of such costs, and Pinole and Hercules shall pay to Rodeo their respective shares of such estimated costs within thirty (30) days after receipt of such bills. Reconciliation of estimated operation and maintenance costs with actual operation and maintenance costs shall

be made by Rodeo, within thirty (30) days following the end of each fiscal year and additional payment to Rodeo or reimbursement by Rodeo, as the case may be, shall be made within said thirty (30) day period.

10. Reclamation Planning. Pinole is hereby authorized to act on behalf of all parties hereto as the coordinating agency for wastewater reclamation planning if such planning entails the use of wastewater from both the Pinole Plant and the Rodeo Plant. If the costs incurred by Pinole in such coordination efforts become substantial, the parties hereto will come to an equitable agreement on the sharing of these costs.

11. Records and Accounts. Rodeo shall keep true and complete records and accounts of all costs of disposal facilities' operation and maintenance and costs of replacement of worn out and obsolete facilities and shall be strictly accountable for all funds and report of all receipts and disbursements. Pinole and Hercules shall have access during reasonable hours to such records and accounts and shall have the right to audit them. Such records and accounts shall be kept in such manner and detail as mutually agreed upon by the parties. Pinole and Rodeo shall keep records on flows and such records shall be available to all parties during reasonable hours. All parties shall have mutual access to flow recorders to determine their respective accuracy.

12. State and Federal Requirements. The State of California and the Federal Government may, through conditions on grants, waste discharge regulations, or plans, impose requirements relating to construction, operation and maintenance, source control, inflow/infiltration, cost sharing, methods of collecting costs, industrial waste ordinances, and other aspects of wastewater management. All parties hereto agree to cooperate with and participate in the implementation of all such requirements.

13. Withdrawal from Agreement. The execution of this agreement is predicated upon the assumption that Federal and State

grants will be available to the parties on a reasonable basis. In the event that such grants are not available or that they are allotted on an unequal percentage basis to the respective parties, any party may withdraw from this Agreement upon giving thirty (30) days written notice to the other parties provided that if said notice is not given within thirty (30) days of the parties being advised of the amount of such grants, this paragraph shall be of no further effect.

14. Agency Consolidation. In case of the consolidation of any of the parties hereto with any other municipality or public entity, this Agreement shall be binding and inure to the benefit of such consolidated municipality or public entity to the extent that the disposal facilities are used by such consolidated municipality or public entity, and any such action shall not otherwise affect this Agreement. Such consolidation shall not increase the capacity allocation or rights of any party.

15. Regulatory Agency Restrictions. If any limitations on the amount of treated wastewater discharged through the disposal facilities are applied to Rodeo by any regulatory agency, the parties hereto will jointly determine the allocation of available capacity to each party to this Agreement. If any limitations on the amount of treated wastewater discharged through the transmission system are applied to Pinole by any regulatory agency, Pinole and Hercules will jointly determine the allocation of available capacity to Pinole and

Hercules. The parties will attempt to consider the intent of the regulatory action in determining the allocations. The parties will also consider the flows being contributed to the disposal facilities and the transmission system by each party at that time and the flow that each party has planned to use in the disposal facilities and transmission system. If any water quality standards are not met in the receiving waters, Pinole, Hercules and Rodeo will jointly attempt to resolve the issue through evaluation of each raw wastewater quality, treatment plant performance, and each plant effluent quality. If the cause of the receiving water violation cannot be attributed to any one party hereto, the parties hereto will jointly determine a course of action to provide compliance with water quality standards.

16. Capacity Allocation. The parties hereto agree that each is guaranteed a flow capacity allocation up to the peak hourly flows shown in Exhibit B. If any party exceeds this amount, that party shall submit a report within thirty (30) days to the other parties hereto describing in detail measures to be implemented to reduce flows to the allocated amounts. The parties hereto may mutually agree on a capacity modification in the disposal facilities for the benefit of one or more parties, and should any agency exceed its designated capacity as shown on Exhibit B herein it may purchase any available unused capacity from any party hereto at a mutually agreed upon price.

17. Mutual Hold Harmless. No party to this Agreement nor any officer or employee thereof shall be responsible for any damage or liability occurring by reason of anything done by any other party to this Agreement under or in connection with any work, authority, or jurisdiction delegated to said other party under this Agreement. It is also understood and agreed that, pursuant to Government Code Section 895.4, each party to this Agreement shall fully indemnify and hold each other party to this Agreement harmless from any liability imposed for injury (as defined in Government Code Section 810.8) occurring by reason of anything done or omitted to be done by said indemnifying party under or in connection with any work, authority, or jurisdiction delegated to said party under this Agreement.

18. Length of Agreement and Periodic Review. This Agreement shall continue in effect for a period of twenty-five (25) years from the date of execution hereof and will renew itself automatically every twenty-five (25) years on the same terms unless one of the parties gives five (5) years notice to the others prior to the expiration of any twenty-five (25) year term of intention to terminate. However, the parties recognize that the elements of this Agreement may be affected by circumstances beyond their control and that final projections for an indefinite period are difficult to make. Accordingly, the parties will, at the request of any one party, review this Agreement and if it causes an unreasonable hard-

ship on any of the parties, appropriate adjustments will be considered.

19. Amendment of Agreement. It is expressly understood and agreed by and between the parties hereto that this Agreement may from time to time and by mutual agreement be altered, amended, and supplemented by and with the consent of the legislative or governing bodies of the parties hereto.

20. Disposition of Assets. Upon termination of this Agreement, any property acquired as the result of the joint exercise of powers and any surplus money on hand shall be returned to the respective parties in proportion to the construction cost contributions actually made by them.

IN WITNESS WHEREOF, the parties have caused this Agreement to be executed by their duly authorized representatives the day and year first above written.

CITY OF PINOLE

By  Mayor

Mayor

CITY OF HERCULES

By  Mayor

Mayor

RODEO SANITARY DISTRICT

By  President

President

EXHIBIT A

PLANS FOR CONNECTION OF PINOLE PIPELINE  
WITH JOINT DISPOSAL FACILITIES  
(to be developed as soon as possible)



EXHIBIT B

Peak hourly wet weather flows used in the design of the disposal facilities:

<u>Agency</u>	<u>Design Flow (mgd)</u>
Pinole	5.82 - 8.4
Hercules	10.25 { 4.43 - 4.43
Rodeo	3.20 - 3.20

Peak hourly wet weather flows used in the design of the transmission system:

<u>Agency</u>	<u>Design Flow (mgd)</u>
Pinole	5.82
Hercules	4.43

## JOINT OUTFALL SURGE RELIEF & AIR RELEASE AGREEMENT

THIS AGREEMENT (herein after referred to as the ("Agreement")) is entered into by and between the Rodeo Sanitary District and the cities of Pinole and Hercules (hereinafter called "the parties"), for the following purpose:

WHEREAS, the parties previously on August 16, 1977 entered into an agreement entitled JOINT EXERCISE OF POWERS AGREEMENT for the purpose of providing a deepwater wastewater disposal facilities consisting of a deepwater outfall and associated onshore facilities hereinafter called "disposal facilities";

WHEREAS, the "disposal facilities" must be modified to include surge relief and air release in order to comply with state and federal environmental requirements;

NOW, THEREFORE, in furtherance of their JOINT EXERCISE OF POWERS AGREEMENT OF August 16, 1977 the "the parties herein agree to constitute themselves as joint venturers, henceforth, "Venturers" for the purposes before mentioned, and intending to be legally bound hereby, the parties hereto, after first being duly sworn, do covenant, agree and certify as follows:

1. The allocation of the actual costs of the project shall be borne by the parties according to the peak hourly weather flows used in design of "the disposal facilities" which were Pinole 3.84, Hercules 6.41, and Rodeo 3.20.
2. All working capital or other funds received by the Joint Venture in connection with the performance of the project shall be deposited in a checking account, set up especially for the joint venture, and requiring the joint signatures of the parties for any withdrawals. Said accounts shall be kept separate and apart from any other accounts of the Venturers. Withdrawal of funds from the Joint Venture's joint checking account may be made in such amount and by such persons as authorized by Venturers.
3. Separate books of account shall be kept by the Administrative Managing Partner of transactions of the Joint Venture. Any of "the parties" may inspect such books upon reasonable notice and at a reasonable time.
4. The Administrative Managing Partner of the Joint Venture shall be the Engineer/Manager of the Rodeo Sanitary District.
5. The Administrative Managing Partner of the Joint Venture is authorized to solicit engineering proposals for the design of the proposed improvements as well as bids to build the improvements. These proposals and bids will be submitted to "the parties" for their respective approvals prior to any contracts being entered into. Each of the parties agrees not to withhold their approvals unreasonably. The parties agree that time is of the essence and each party agrees to seek approvals of engineering proposals and bids as soon as reasonably possible.
6. Once an engineering proposal is accepted by the parties, each party will transmit its

proportionate amount of the estimated fees and costs therefore to the Administrative Managing Partner of the Joint Venture who shall deposit said funds in the Joint Venture bank account for dispersal to said engineers.

7. Once a construction bid is accepted by the parties, each party will transmit its proportionate amount of the estimated fees and costs therefore to the Administrative Managing Partner of the Joint Venture who shall deposit said funds in the Joint Venture bank account for dispersal to said contractors.
8. This agreement, read in conjunction with and relating back to the August 19, 1977 Joint Exercise of Powers Agreement, constitutes the entire agreement of the parties and may not be altered, unless the same is agreed upon in writing signed by the parties.

Dated this the 1<sup>st</sup>, day of APRIL, 2004.

  
\_\_\_\_\_  
City of Pinole

  
\_\_\_\_\_  
City of Hercules

  
\_\_\_\_\_  
Rodeo Sanitary District